

# legnoform



Lo stile italiano apre le porte

# Indice

## Index

Cornici	14
Rombi	30
Formelle	44
Le Cifre	58
Intarsio	76
Le Radiche	94
Veneziana	110
I Laccati	140
Pergamenata	158
Decapata	170
Impero	184
Liberty	206
Country	250
Consumata	268
Arte Povera	282
Rovinò	298
Classici e Anticati	312
Capitelli e Coprifili/Doorheads and Casings	370
Prima	378
Alta Ebanisteria	392
Legni & Lacche	406



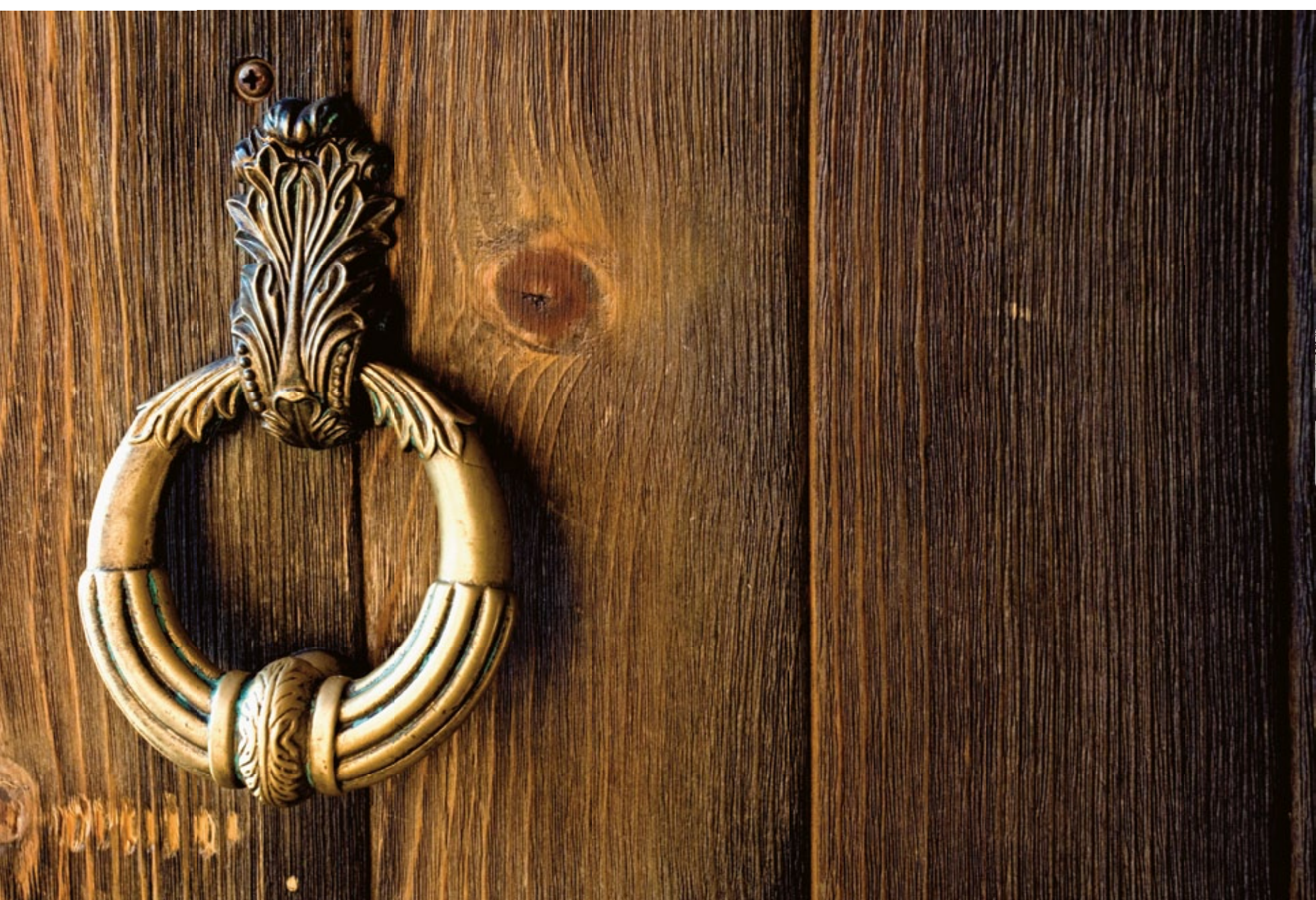

# *Il legno una storia*

Dal legno nascono forme che diventano quotidianità, passano attraverso il tempo, si tramandano. Storie che diventano tradizione, famiglia, vita.

*Wood is a  
story in itself*

Wood can be turned into timeless designs and become everyday life, which are handed down through the generations. Stories that become tradition, family, life.





## *Dalla materia alla forma*

Legnoform intuisce, pensa e realizza porte con la sapienza di chi, da oltre 60 anni, disegna idee, apre a nuovi stili, accompagna l'anima del legno in tanti spazi. Fino a trasformarli in ambienti.

Un connubio di artigianalità e nuove tecnologie, per dare alla luce Collezioni di grande prestigio, in legno massello. Capaci di scaldare una forma e plasmarla intorno a ogni personalità.

## *Matter becomes form*

Legnoform senses, thinks and creates doors with all the know-how of over 60 years, designing ideas, receptive to new styles which it develops into environments. A marriage of craftsmanship and new technologies which has given birth to prestigious doors Collections in solid wood, able to give warmth to a shape and mould it around any personality.





# *Le nostre collezioni vivono in armonia*

In armonia con chi le produce, perché amiamo trasferire in loro tutto l'amore e la conoscenza di un grande lavoro manuale, fatto di sensibilità e cuore. In armonia con chi le acquista, perché realizzano

un desiderio. E in armonia con la natura, perché sono realizzate con legnami provenienti da foreste gestite in maniera sostenibile e soggette a riforestazione programmata.

# *Our collections live in harmony*

In harmony with those who manufacture them, since we love embedding in them all the love and know-how of great craftsmanship, full of sensitivity and heart. In harmony with those who purchase

them, since they fulfil a wish. And in harmony with nature, since they are produced with wood from sustainably managed forests undergoing reforestation.



Legnoform, sempre attenta alla salvaguardia e alla tutela dell'ambiente, ha stampato questa documentazione su carta proveniente da foreste correttamente gestite e da altre origini controllate certificate dal Forest Stewardship Council (FSC).

Protecting and defending the environment matters to us here in Legnoform. This brochure has been printed on paper from responsibly managed forests and other sources checked and certified by the Forest Stewardship Council (FSC).



**legnoform**





# *Made in Legnoform* *Made in Italy*

L'orgoglio di creare un prodotto che si distingue, forte di una progettazione, un'artigianalità e una realizzazione che nascono esclusivamente sul territorio italiano.

Made in Italy significa scegliere una creatività unica, un'esperienza ed una passione che da

The pride in creating a distinctive product distinguished by its strength, design and craftsmanship, and manufactured exclusively in Italy.

Made in Italy means choosing a unique creativity, experience and passion that for generations has

generazioni trasformano la materia in un prodotto inconfondibile, che parla di sé in una lingua universale.

Perché sappiamo chi siamo, da dove veniamo e dove vogliamo arrivare.

Oltre ogni confine.

moulded matter into an unequalled product which speaks for itself in a universal language.

Because we know who we are, where we come from and where we are going.

Beyond all limits.





Lasciare un segno, giocare con la materia,  
esaltandola, grazie ad un lavoro artigianale  
raffinato e di altissima fattura.

Leaving its mark, playing with materials,  
enhancing them through refined and highly skilled  
craftsmanship.

*Cornici* pag. 14

*Rombi* pag. 30

*Formelle* pag. 44

*Le Cifre* pag. 58

*Intarsio* pag. 76

*Le Radiche* pag. 94



*Cornici*



# Cornici

Una forma che nasce intorno a quella originale: spazio che contiene il pannello, nella stessa essenza della porta, moltiplicandone impatto e importanza. I pannelli si impreziosiscono con un particolare profilo che crea profondità, impercettibili rilievi che seguono la forma originale. La finitura è impreziosita da uno zoccolo inserito a incastro nella traversa inferiore del battente.

A new shape is born from within the original: space encasing the doorleaf in the same wood finish as the door, thus increasing its impact and value. The panels are enriched by a distinctive profiling which creates depth, imperceptible relief following the original shape. This finish is embellished by a plinth in the lower crosspiece of the doorleaf.



cod. 5-31 Alder anticato noce  
chiaro - capitello lineare  
coprifili standard.

code 5-31 Alder stained antique  
light walnut - Flat doorhead  
standard casings.

# Cornici

legnoform





cod. 2-11 Alder anticato noce  
chiaro - capitello lineare con  
rosette - coprifili standard.

code 2-11 Alder stained antique  
light walnut - Flat doorhead with  
turned blocks - standard casings.



cod. 6-14 Alder anticato noce  
chiaro - capitello centinato  
coprifili standard.

code 6-14 Alder stained antique  
light walnut - Bowed doorhead  
standard casings.





Porte in legno massello di Alder con cornici inserite ad incastro nel pannello. Disponibili in due finiture: anticato noce chiaro e anticato noce scuro.

Solid wood Alder doors with profiling embedded in the panel. Two finishes available: antique light walnut and antique dark walnut.



cod. 5-32 Alder anticato noce scuro - capitello lineare coprifili standard.

code 5-32 Alder stained antique dark walnut - Flat doorhead standard casings.

Cornici

legnoform





cod. 7R-18 Alder anticato noce  
scuro - cristallo legato ottone  
capitello 700R - coprifili lisci.

code 7R-18 Alder stained antique  
dark walnut - brass beading glass  
700R doorhead, smooth casings.



cod. 7R-17 Alder anticato noce  
scuro - capitello 700R - coprifili  
lisci.

code 7R-17 Alder stained antique  
dark walnut - 700R doorhead,  
smooth casings.

*Cornici*

**legnoform**



cod. 2-14 Alder anticato noce  
scuro - capitello timpano  
interrotto - coprifili standard.

code 2-14 Alder stained antique  
dark walnut - Broken gable  
doorhead - standard casings.



cod. 2-13 Alder anticato noce  
scuro - cristallo legato ottone  
capitello lineare - coprifili  
standard.

code 2-13 Alder stained antique  
dark walnut - brass beading glass  
Flat doorhead - standard casings.



# Le Soluzioni *The Solutions*

Immagina la porta dei tuoi desideri. Immaginala in casa tua, in un ambiente dove vivere una quotidianità piacevole, appagante, di stile. E immaginala esattamente come vuoi, perché qualunque sia la sua forma, possiamo realizzarla. Grazie alla maestria artigiana Legnoform, sono disponibili soluzioni speciali che consentono di realizzare ogni tua esigenza, con interventi unici realmente a misura di desiderio. Il tuo.

Imagine the door of your wish. Imagine it in your own home, a surrounding in which you can live a gratifying, pleasant and stylish everyday life. And imagine it exactly as you wish and with whatever shape, we can produce it. Legnoform's masterful craftsmanship will allow you to have special solutions uniquely tailored to a wish – your very own.

Alcuni esempi di soluzioni speciali - Some examples of special solutions

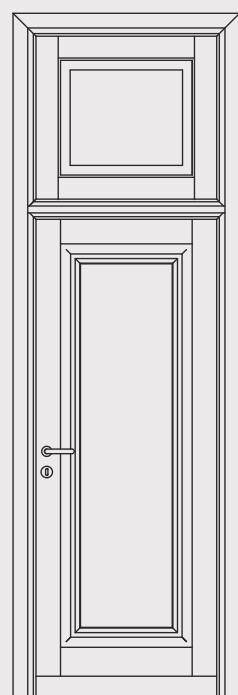

Sopraluce con battente  
Transom with doorleaf

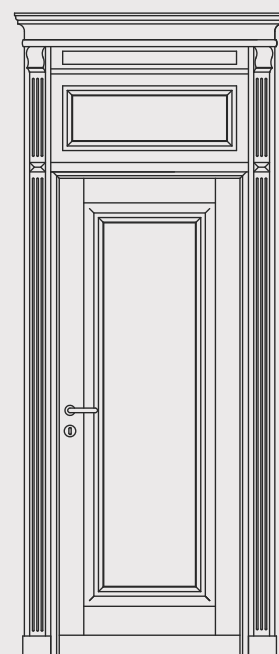

Chiambrana  
"Chiambrana"

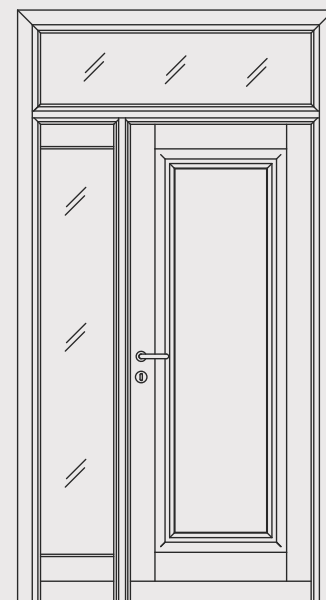

Fianco-luce e sopraluce  
Sidelight with transom window

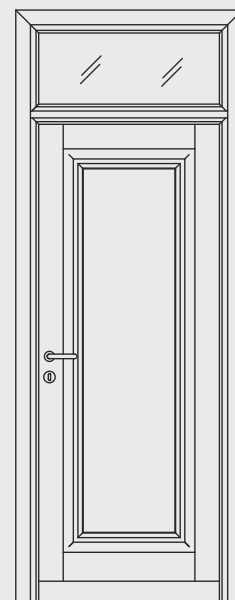

Sopraluce a vetro  
Transom window

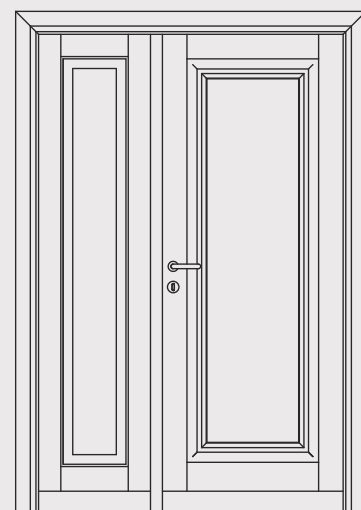

Doppia asimmetrica  
Asymmetrical double door





# Cornici

Porte in legno massello di Nocino Americano - Alder con cornici e zocolino inseriti ad incastro. Ogni modello è disponibile nella versione a 2 battenti e predisposto per vetro. Coprifili standard con taglio a 45°.

Solid wood Alder doors with embedded profiling and plinth. Each model is available in the double-door version and can be fitted with glass. Standard 45° casings.

## I Modelli - The Models

La lavorazione Cornici è disponibile su tutte le Serie Legnoform, ad eccezione delle Serie 100, 400, 700, 800R, 800 e 900.

The "Cornici" finish is available on all Legnoform's Series, with the exception of Serie 100, 400, 700, 800R, 800 and 900.

## Le Finiture Legno - The Wood Finishes



Alder anticato noce chiaro  
Alder stained antique light walnut



Alder anticato noce scuro  
Alder stained antique dark walnut

## I Cristalli - The Glass



Legato ottone satinato  
bianco - bisello lucido  
White satin - clear bevelled with  
brass beading



Doppio legato ottone satinato  
bianco/bronzo  
Satin white/bronze with  
double antique brass beading

## Le Cerniere - The Hinges

Cerniera in Stile,  
a pomella in ottone  
Old fashioned pintel  
hinge in brass



Finitura ottone  
satinato  
Mat brass finish

## Capitelli e coprifili - Doorheads and casings

Le porte Cornici vengono fornite complete di coprifili standard a 45°. Capitelli e coprifili speciali disponibili a richiesta. Vedi anche approfondimento Sezione Capitelli pag. 370.

The Cornici doors are supplied with standard 45° casings. Doorheads and special casings available upon request. See also the detailed section of doorheads and casings at page 370.

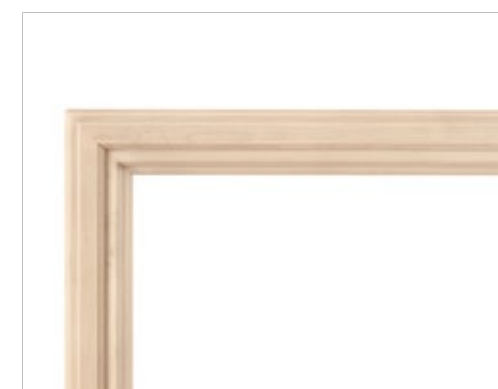

cm 6,4  
Coprifili standard  
Standard casings



Capitello Lineare con coprifili standard  
Flat doorhead with standard casings



Capitello Lineare con rosette con coprifili standard  
Flat doorhead with turned blocks and standard casings



Capitello Centinato con coprifili standard  
Bowed doorhead with standard casings



Capitello a Timpano con coprifili standard  
Gable doorhead with standard casings



cm 11,5  
Capitello Quadrato con coprifili mod. Bastoncino rigato  
Square doorhead with casings mod. Striped strip



cm 11,5  
Capitello Timpano interrotto - coprifili mod. Mensola liscia  
Broken gable doorhead with casings mod. Smooth corbel



cm 11,5  
Capitello Timpano con coprifili mod. Mensola rigata  
Gable doorhead with casings mod. Striped corbel



cm 11,5  
Capitello Lineare con coprifili mod. Bastoncino rigato  
Flat doorhead with casings mod. Striped strip



*Rombi.*



# Rombi

Una decorazione preziosa, una linea retta che taglia il massello, lo impreziosisce, lo evidenzia, crea una sottile chiave di chiaroscuro che diventa profondità.

Una lavorazione importante, la forza geometrica di una forma che prende possesso dello spazio e lo eleva.

A sumptuous decoration, a straight line cutting the solid wood, enriching it, heightening it and creating a subtle light and shade effect that becomes depth.

Bold workmanship, the geometric power of a shape that takes possession of space and enhances it.

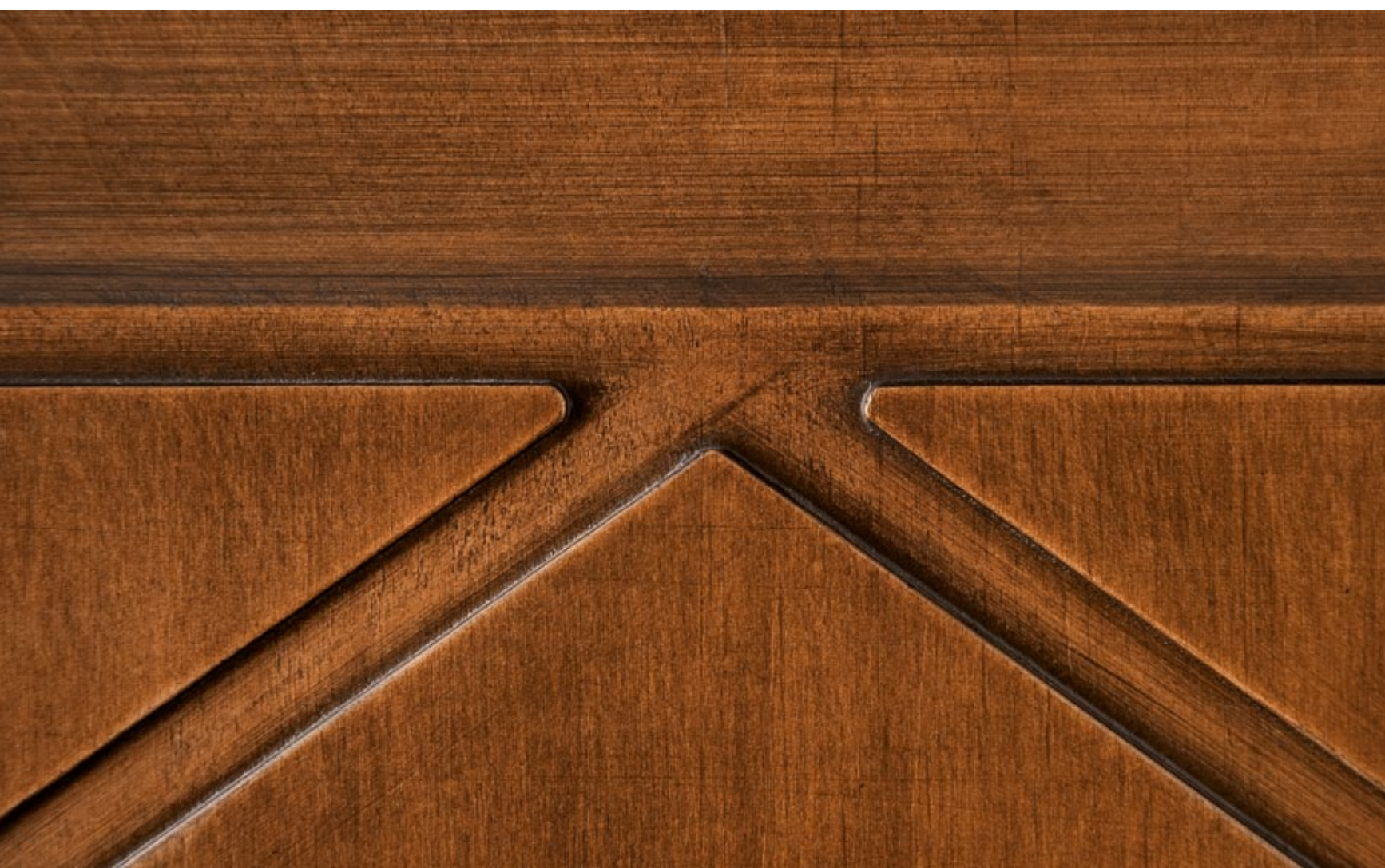

cod. 2-14 Alder anticato noce scuro - coprifili lisci.

code 2-14 Alder stained antique dark walnut - smooth casings.

# Rombi

legnoform





cod. 2-11 Alder anticato noce  
scuro - capitello Rombi  
coprifili lisci.

code 2-11 Alder stained antique  
dark walnut - "Rombi" doorhead  
smooth casings.



cod. 5-40 Alder anticato noce  
scuro - capitello Rombi  
coprifili lisci.

code 5-40 Alder stained antique  
dark walnut - "Rombi" doorhead  
smooth casings.

*Rombi*

**legnoform**



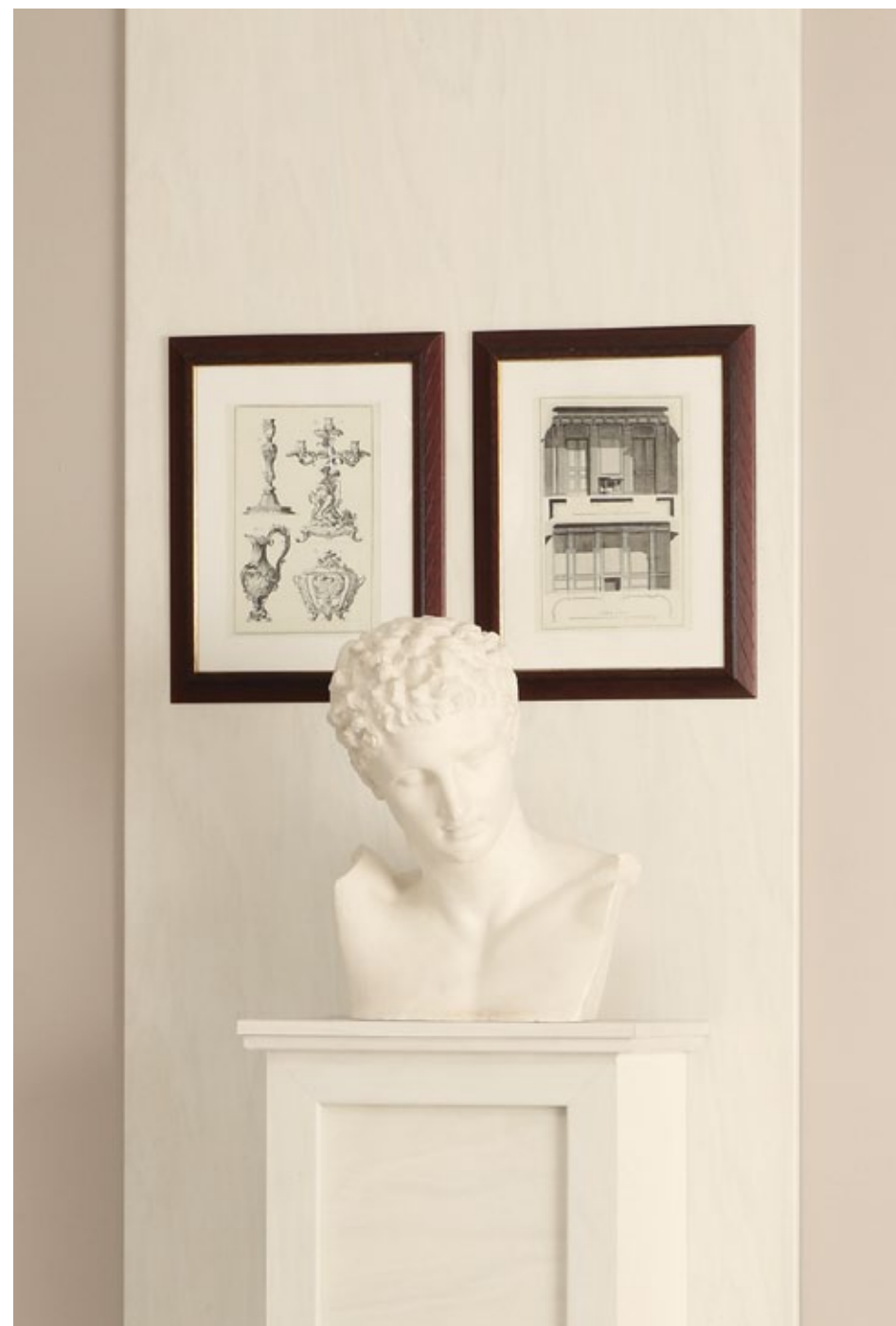

Porte in legno massello di Alder con pannelli intagliati a rombi disponibili in due finiture: anticato noce chiaro e anticato noce scuro.

Solid wood Alder doors with carved out panels available in two finishes: antique light walnut and antique dark walnut.



cod. 5-32 Alder anticato noce scuro - capitello Rombi coprifili mod. mensola rigata e zoccolino.

code 5-32 Alder stained antique dark walnut - "Rombi" doorhead with casings mod. Striped corbel and plinth.

Rombi

legnoform





cod. 2-11 Alder anticato noce chiaro - capitello Rombi coprifili mod. Bastoncino rigato e zoccolino.

code 2-11 Alder stained antique light walnut - "Rombi" doorhead with casings mod. Striped strip and plinth.



cod. 2-14 Alder anticato noce chiaro capitello Rombi - coprifili lisci.

code 2-14 Alder stained antique light walnut "Rombi" doorhead - smooth casings.



cod. 5-31 Alder anticato noce chiaro coprifili lisci.

code 5-31 Alder stained antique light walnut - smooth casings.

Rombi



# Le Soluzioni The Solutions

Immagina la porta dei tuoi desideri. Immaginala in casa tua, in un ambiente dove vivere una quotidianità piacevole, appagante, di stile. E immaginala esattamente come vuoi, perché qualunque sia la sua forma, possiamo realizzarla. Grazie alla maestria artigiana Legnoform, sono disponibili soluzioni speciali che consentono di realizzare ogni tua esigenza, con interventi unici realmente a misura di desiderio. Il tuo.

Imagine the door of your wish. Imagine it in your own home, a surrounding in which you can live a gratifying, pleasant and stylish everyday life. And imagine it exactly as you wish and with whatever shape, we can produce it. Legnoform's masterful craftsmanship will allow you to have special solutions uniquely tailored to a wish – your very own.

Alcuni esempi di soluzioni speciali  
Some examples of special solutions

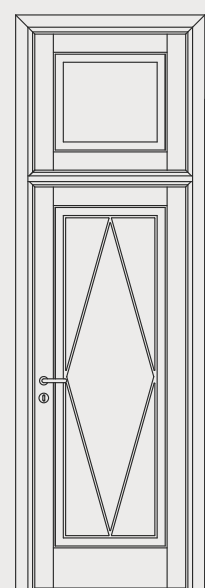

Sopraluce con battente  
Transom with doorleaf

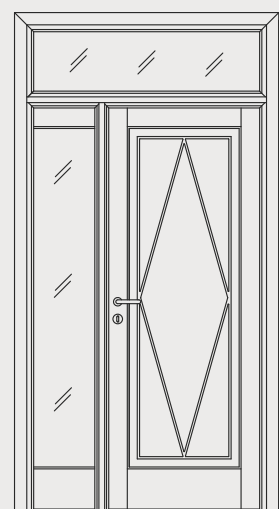

Fianco-luce e sopraluce  
Sidelight with transom window

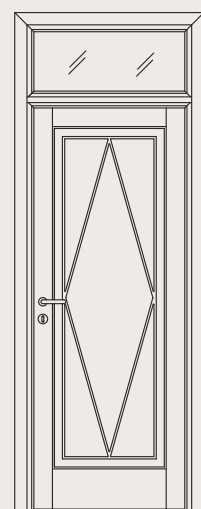

Sopraluce a vetro  
Transom window



Soluzione porta cod. 2-11 in Alder anticato noce scuro con Chiambrana Rombi completa di capitello - coprifili mod. mensola rigata e zoccolino.

Door solution code 2-11 in Alder stained antique dark walnut with "Chiambrana" Rombi supplied with doorhead - casings mod. Striped corbel and plinth.

# Rombi

legnoform

# Rombi

Porte in legno massello di Nocino Americano - Alder con pannelli intagliati. Ogni modello è disponibile nella versione a 2 battenti e predisposto per vetro. Coprifili lisci, con taglio a 45°.

Solid wood Alder doors with carved out panels. Each model is available in the double-door version and can be fitted with glass. Smooth casings with 45° cut.

## I Modelli - The Models

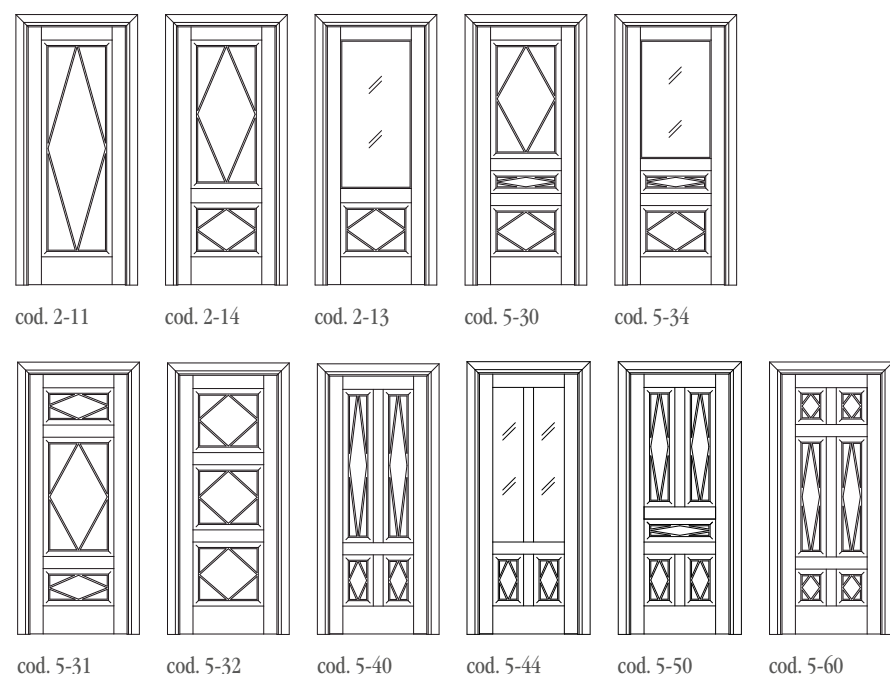

cod. 2-11    cod. 2-14    cod. 2-13    cod. 5-30    cod. 5-34

cod. 5-31    cod. 5-32    cod. 5-40    cod. 5-44    cod. 5-50    cod. 5-60

## Le Finiture Legno - The Wood Finishes



Alder anticato noce chiaro  
Alder stained antique light walnut



Alder anticato noce scuro  
Alder stained antique dark walnut

## I Cristalli - The Glass

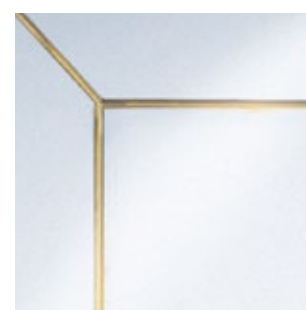

Legato ottone satinato bianco bisello lucido  
White satin - clear bevelled with brass beading



Doppio legato ottone satinato bianco/bronzo  
Satin white/bronze with double antique brass beading

## Le Cerniere - The Hinges

Cerniera in Stile, a pomella in ottone  
Old fashioned pintel hinge in brass



Finitura ottone satinato  
Mat brass finish

## Capitelli e coprifili - Doorheads and casings

Le porte Rombi vengono fornite complete di coprifili lisci, taglio a 45°. Capitello Rombi disponibile a richiesta con coprifili lisci o speciali da cm 11,5 realizzabili in 4 modelli con zoccolino. Vedi anche approfondimento Sezione Capitelli pag. 370.

The Rombi doors are supplied with smooth casings, 45° cut. Rombi doorhead available either with smooth casings or special ones 11,5 cm wide in 4 models with plinth. See also the detailed section of doorheads and casings at page 370.



cm 6,4

Coprifili lisci  
Smooth casings

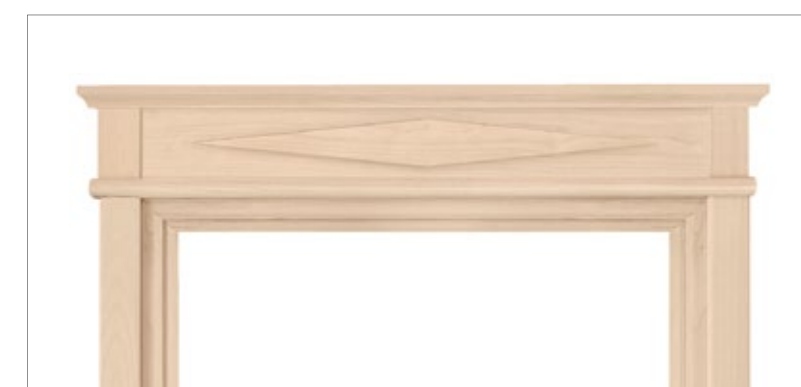

Capitello Rombi con coprifili lisci  
Rombi doorhead with smooth casings



cm 11,5

Capitello Rombi con coprifili mod. Bastoncino liscio  
Rombi doorhead with casings mod. Smooth strip

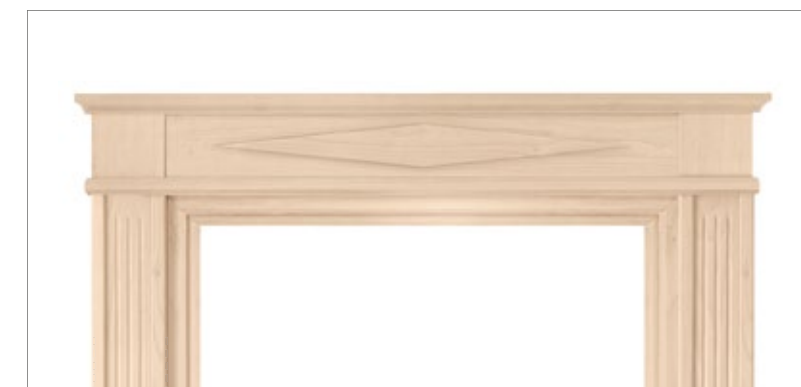

cm 11,5

Capitello Rombi con coprifili mod. Bastoncino rigato  
Rombi doorhead with casings mod. Striped strip

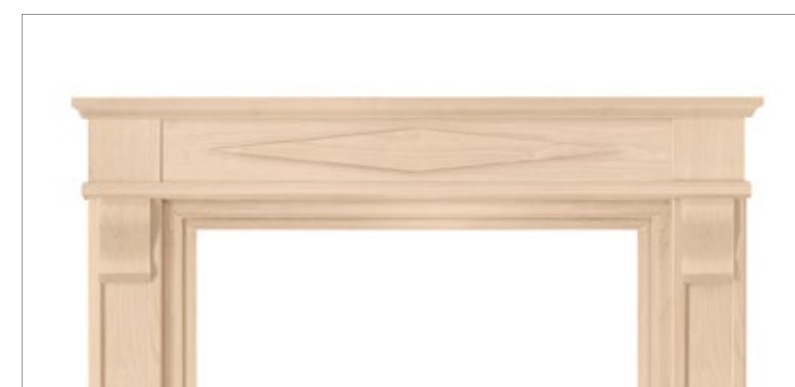

cm 11,5

Capitello Rombi con coprifili mod. Mensola liscia  
Rombi doorhead with casings mod. Smooth corbel

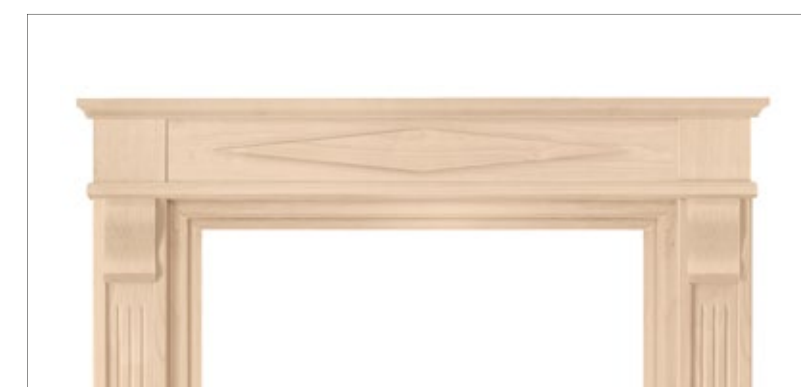

cm 11,5

Capitello Rombi con coprifili mod. Mensola rigata  
Rombi doorhead with casings mod. Striped corbel





*Formelle*



# Formelle

La tradizione ottocentesca che si fa forma, uno stile senza tempo che riafferma i suoi valori. Il profilo del pannello in massello viene intagliato a formelle: tondità formali si alternano a eleganti curvature, come linee tracciate dalla mano di un pittore. Un insieme raffinato, che si distingue nel dettaglio.

Nineteenth Century tradition takes shape, a timeless style reaffirms its values. The profile of the solid wood panel is cut into "Formelle": formal roundness alternating with stylish curves, like an artist's brush strokes. A refined whole which distinguishes itself in the detail.



cod. 5-32 Alder anticato noce scuro - capitello Formelle coprifili lisci.

code 5-32 Alder stained antique dark walnut - "Formelle" doorhead with smooth casings.

# Formelle

legnoform





cod. 2-14 Alder anticato noce  
scuro - capitello Formelle  
coprifili lisci.

code 2-14 Alder stained antique  
dark walnut - "Formelle" doorhead  
with smooth casings.



cod. 5-31 Alder anticato noce  
scuro - capitello Formelle  
coprifili lisci.

code 5-31 Alder stained antique  
dark walnut - "Formelle" doorhead  
with smooth casings.

*Formelle*

**legnoform**



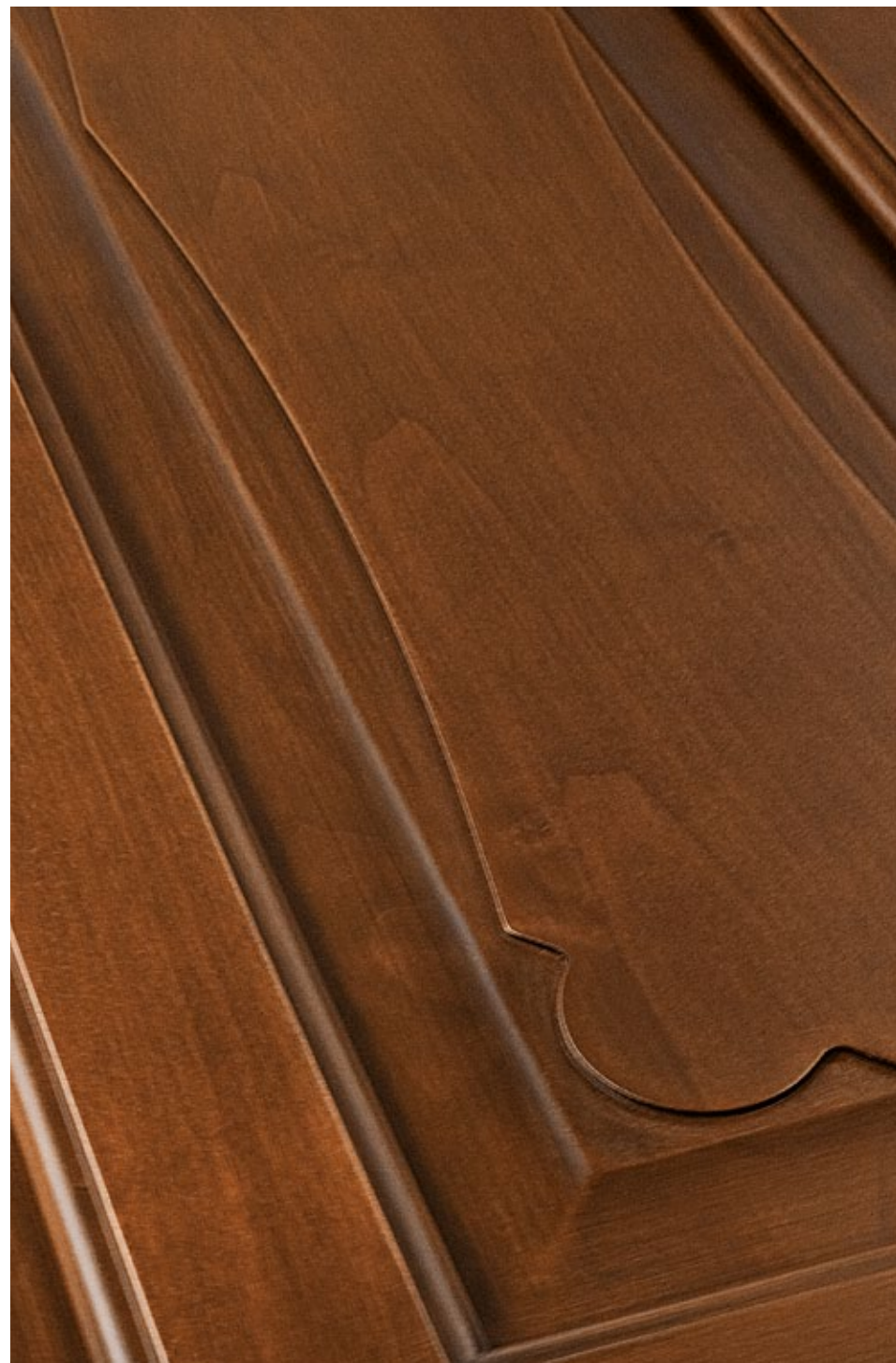

Porte in legno massello di Alder con pannelli intagliati a formelle disponibili in due finiture: anticato noce chiaro e anticato noce scuro.

Solid wood Alder doors with carved out panels available in two finishes: antique light walnut and antique dark walnut.



cod. 5-60 Alder anticato noce scuro - coprifili lisci.

code 5-60 Alder stained antique dark walnut - smooth casings.

Formelle

legnoform





cod. 2-11 Alder anticato noce  
chiaro - capitello Timpano  
coprifili mod. Mensola liscia e  
zoccolino.

code 2-11 Alder stained antique  
light walnut - Gable doorhead with  
casings mod. Smooth Corbel and  
plinth.



cod. 2-14 Alder anticato noce  
chiaro - coprifili lisci.

code 2-14 Alder stained antique  
light walnut - smooth casings.

*Formelle*

**legnoform**



# Le Soluzioni The Solutions

Immagina la porta dei tuoi desideri. Immaginala in casa tua, in un ambiente dove vivere una quotidianità piacevole, appagante, di stile. E immaginala esattamente come vuoi, perché qualunque sia la sua forma, possiamo realizzarla. Grazie alla maestria artigiana Legnoform, sono disponibili soluzioni speciali che consentono di realizzare ogni tua esigenza, con interventi unici realmente a misura di desiderio. Il tuo.

Imagine the door of your wish. Imagine it in your own home, a surrounding in which you can live a gratifying, pleasant and stylish everyday life. And imagine it exactly as you wish and with whatever shape, we can produce it. Legnoform's masterful craftsmanship will allow you to have special solutions uniquely tailored to a wish – your very own.

Alcuni esempi di soluzioni speciali  
Some examples of special solutions



Sopraluce con battente  
Transom with doorleaf

Chiambrana  
"Chiambrana"

Fianco-luce e sopraluce  
Sidelight with transom window



Soluzione porta cod. 2-14 in Alder anticato noce scuro con sopraluce con cristallo satinato bianco - bisello lucido. Completa di capitello lineare - coprifili mod. mensola rigata e zoccolino.  
Door solution code 2-14 in Alder stained antique dark walnut with transom window with white satin clear bevelled glass. Supplied with Flat doorhead - casings mod. Striped corbel and plinth.

# Formelle

legnoform

# Formelle

Porte in legno massello di Nocino Americano - Alder con pannelli intagliati. Ogni modello è disponibile nella versione a 2 battenti e predisposto per vetro. Coprifili lisci con taglio a 45°.

Solid wood Alder doors with carved out panels. Each model is available in the double-door version and can be fitted with glass. Smooth casings, with 45° cut.

## I Modelli - The Models



cod. 2-11    cod. 2-14    cod. 2-13    cod. 5-30    cod. 5-34

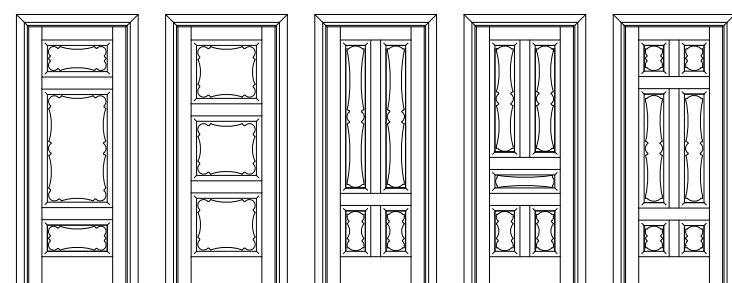

cod. 5-31    cod. 5-32    cod. 5-40    cod. 5-50    cod. 5-60

## Le Finiture Legno - The Wood Finishes



Alder anticato noce chiaro  
Alder stained antique light walnut



Alder anticato noce scuro  
Alder stained antique dark walnut

## I Cristalli - The Glass

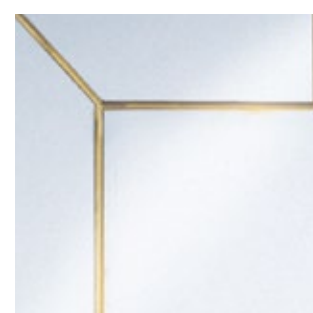

Legato ottone satinato bianco bisello lucido  
White satin - clear bevelled with brass beading



Doppio legato ottone satinato bianco/bronzo  
Satin white/bronze with double antique brass beading

## Le Cerniere - The Hinges

Cerniera in Stile, a pomella in ottone  
Old fashioned pintel hinge in brass



Finitura ottone satinato  
Mat brass finish

## Capitelli e coprifili - Doorheads and casings

Le porte Formelle vengono fornite complete di coprifili lisci, taglio a 45°. Capitello Formelle disponibile a richiesta con coprifili lisci o speciali da cm 11,5 realizzabili in 4 modelli con zoccolino. Vedi anche approfondimento Sezione Capitelli pag. 370.

The Formelle doors are supplied with smooth casings, 45° cut. Formelle doorhead available either with smooth casings or special ones 11,5 cm wide in 4 models with plinth. See also the detailed section of doorheads and casings at page 370.



cm 6,4  
Coprifili lisci  
Smooth casings

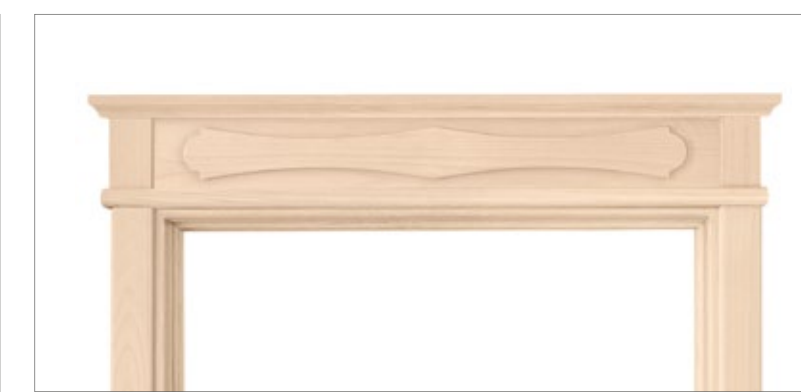

Capitello Formelle con coprifili lisci  
Formelle doorhead with smooth casings



cm 11,5  
Capitello Formelle con coprifili mod. Bastoncino liscio  
Formelle doorhead with casings mod. Smooth strip



cm 11,5  
Capitello Formelle con coprifili mod. Bastoncino rigato  
Formelle doorhead with casings mod. Striped strip



cm 11,5  
Capitello Formelle con coprifili mod. Mensola liscia  
Formelle doorhead with casings mod. Smooth corbel

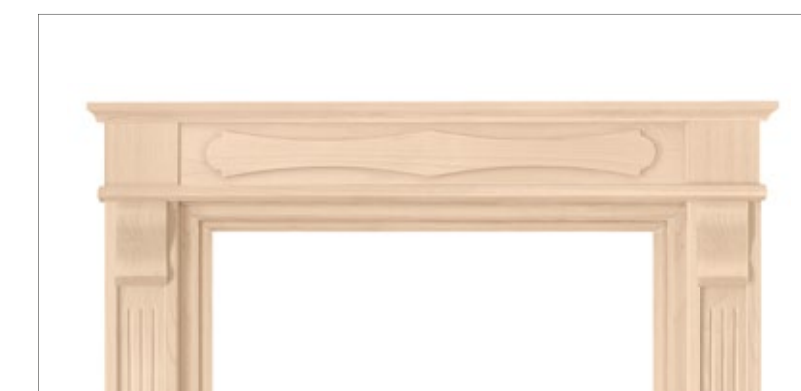

cm 11,5  
Capitello Formelle con coprifili mod. Mensola rigata  
Formelle doorhead with casings mod. Striped corbel



*Le Cifre*





# Le Cifre

La differenza tra meraviglia e unicità, è in due lettere. Le tue. Perché una porta Legnoform può essere personalizzata con le tue iniziali: una preziosa intarsiatura di bronzo su radica, un elegante dettaglio che sposa la voglia di distinguersi. Perché sono le piccole cose a rendere speciali quelle grandi.

We find the difference between wonder and uniqueness in two letters – your own. For a Legnoform door can be customized with your initials: a rich bronze inlay on briar-wood, an elegant detail in union with the wish to be distinguished. Because it's the little things that make the big ones special.



cod. 2-14 Alder anticato noce chiaro - capitello quadrato coprifili mod. mensola rigata e zoccolino.

code 2-14 Alder stained antique light walnut - Square doorhead with casings mod. Striped corbel and plinth.

# Le Cifre

legnoform





cod. 2-11 Alder anticato noce  
chiaro - capitello quadrato con  
coprifili mod. mensola rigata e  
zoccolino.

code 2-11 Alder stained antique  
light walnut - Square doorhead  
with casings mod. Striped corbel  
and plinth.



cod. 2-12 Alder anticato noce  
chiaro - cristallo inciso Le Cifre  
capitello lineare - coprifili  
standard.

code 2-12 Alder stained antique  
light walnut - bevelled glass detail  
Le Cifre - Flat doorhead - standard  
casings.

Le Cifre

legnoform



cod. 2-11 Alder anticato noce scuro - capitello lineare con rosette - coprifili standard.

code 2-11 Alder stained antique dark walnut - Flat doorhead with turned blocks and standard casings.



cod. 5-31 Alder anticato noce scuro - capitello timpano interrotto - coprifili mod. mensola rigata e zoccolino.

code 5-31 Alder stained antique dark walnut - Broken gable doorhead with casings mod. Striped corbel and plinth.



Le Cifre

legnoform





cod. 5-31 Alder finitura Veneziana - capitello lineare con rosette - coprifili standard.  
code 5-31 Alder Veneziana finish - Flat doorhead with turned blocks - standard casings.

Una firma che distingue. Le tue iniziali al centro, intorno al quale si irradia la luminosità di un capolavoro. Cifre di preziosità.

The luminosity of a masterpiece shines out from your very own initials in the centre of the door. This is the richness of the Cifre collection.

Le Cifre







cod. 2-11 Alder finitura  
Veneziana - capitello centinato  
coprifili mod. mensola liscia  
e zoccolino.

code 2-11 Alder Veneziana finish  
Bowed doorhead with casings mod.  
Smooth corbel and plinth.



cod. 2-14 Alder finitura  
Veneziana - capitello lineare  
con rosette e coprifili standard.

code 2-14 Alder Veneziana finish  
Flat doorhead with turned blocks  
and standard casings.

*Le Cifre*

**legnoform**



# Le Soluzioni The Solutions

Immagina la porta dei tuoi desideri. Immaginala in casa tua, in un ambiente dove vivere una quotidianità piacevole, appagante, di stile. E immaginala esattamente come vuoi, perché qualunque sia la sua forma, possiamo realizzarla. Grazie alla maestria artigiana Legnoform, sono disponibili soluzioni speciali che consentono di realizzare ogni tua esigenza, con interventi unici realmente a misura di desiderio. Il tuo.

Imagine the door of your wish. Imagine it in your own home, a surrounding in which you can live a gratifying, pleasant and stylish everyday life. And imagine it exactly as you wish and with whatever shape, we can produce it. Legnoform's masterful craftsmanship will allow you to have special solutions uniquely tailored to a wish – your very own.

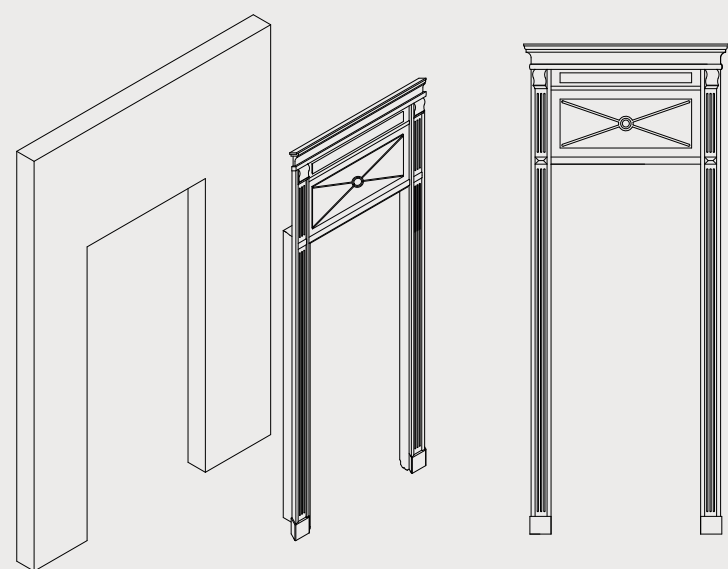

Le Chiambrane Legnoform, soluzioni dal grande impatto visivo che permettono di essere installate senza apporre alcuna modifica muraria. Disponibili su tutti i modelli Legnoform.

“Le Chiambrane” Legnoform, exceptionally eye-catching solutions that can be installed without changing the wall openings. Available on all Legnoform's models.



Soluzione porta cod. 2-11 in Alder anticato noce chiaro con Chiambrana Le Cifre completa di capitello - coprifili mod. mensola rigata e zoccolino.

Door solution code 2-11 in Alder stained antique light walnut with “Chiambrana” Le Cifre supplied with doorhead - casings mod. Striped corbel and plinth.

# Le Cifre

legnoform



# Le Soluzioni The Solutions

Per i fuori misura Legnoform propone un'ampia gamma di soluzioni speciali che consentono di realizzare ogni tua esigenza, con interventi unici realmente a misura di desiderio.

For non standard measures, Legnoform suggests a wide range of special solutions which allow you to have special and bespoke items, uniquely tailored to your requirements.

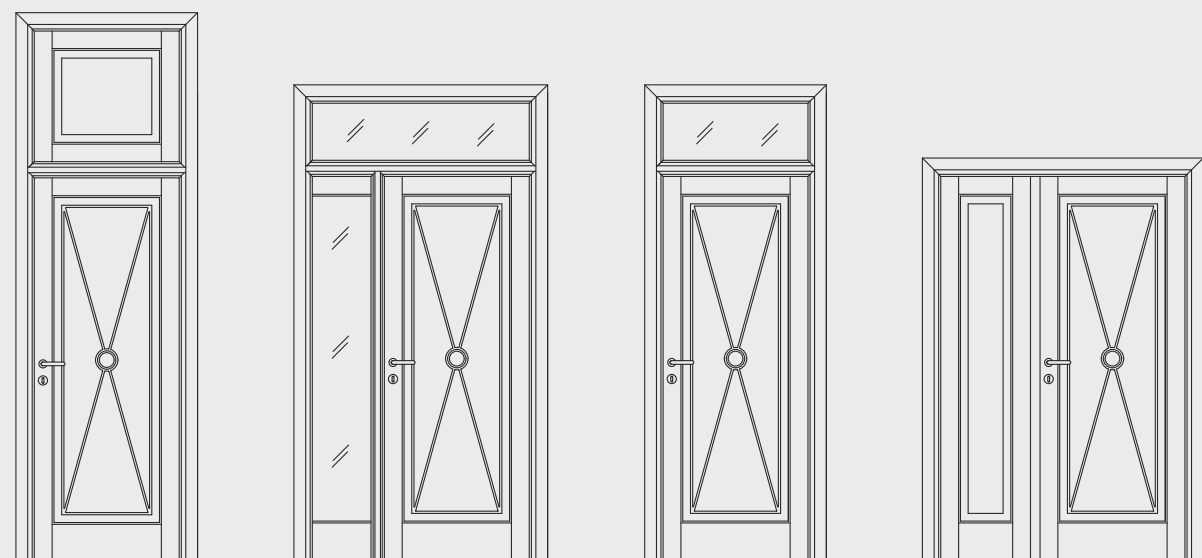

Alcuni esempi di soluzioni speciali  
Some examples of special solutions

Sopraluce con battente  
Transom with doorleaf  
Fianco-luce e sopraluce  
Sidelight with transom window  
Sopraluce a vetro  
Transom window  
Doppia asimmetrica  
Asymmetrical double door



Soluzione porta cod. 2-11 in Alder anticato noce chiaro con doppio fianco-luce e sopraluce con cristallo satinato bianco bisello lucido. Capitello lineare - coprifili mod. mensola rigata e zoccolino.

Door solution code 2-11 in Alder stained antique light walnut with double side-lights and transom windows with white satin clear bevelled glass. Flat doorhead - casings mod. Striped corbel and plinth.

# Le Cifre

legnoform



# Le Cifre

Porte in legno massello di Nocino Americano - Alder con pannelli intagliati e lettere intarsiate. Ogni modello è disponibile nella versione a 2 battenti e predisposto per vetro. Coprifili standard a 45°.

Solid wood Alder doors with carved out panels and inlayed letters. Each model is available in the double-door version and can be fitted with glass. Standard 45° casings.

## I Modelli - The Models

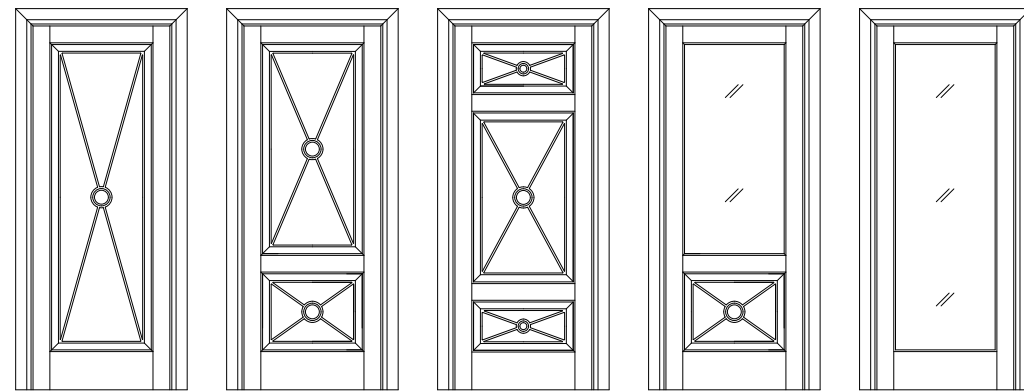

cod. 2-11

cod. 2-14

cod. 5-31

cod. 2-13

cod. 2-12

## Le Finiture Legno - The Wood Finishes



Alder anticato noce chiaro  
Alder stained antique light walnut



Alder anticato noce scuro  
Alder stained antique dark walnut



Alder finitura Veneziana  
Alder Veneziana finish

## I Cristalli - The Glass

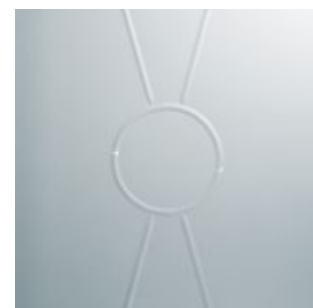

Inciso disegno Le Cifre - satinato bianco con incisione e bisello lucido  
Bevel detail Le Cifre - white satin clear bevelled

## Le Cerniere - The Hinges

Cerniera in Stile, a pomella, in ottone o in ferro  
Old fashioned pintel hinge in brass or in iron



Finitura ottone satinato  
Mat brass finish



Finitura brunita  
Burnished finish

## Capitelli e coprifili - Doorheads and casings

Le porte Le Cifre vengono fornite complete di coprifili standard a 45°. Capitelli e coprifili speciali disponibili a richiesta. Vedi anche approfondimento Sezione Capitelli pag. 370.

The Le Cifre doors are supplied with standard 45° casings. Doorheads and special casings available upon request. See also the detailed section of doorheads and casings at page 370.



cm 6,4

Coprifili standard  
Standard casings



Capitello Lineare con coprifili standard  
Flat doorhead with standard casings



Capitello Lineare con rosette con coprifili standard  
Flat doorhead with turned blocks and standard casings



Capitello Centinato con coprifili standard  
Bowed doorhead with standard casings



Capitello a Timpano con coprifili standard  
Gable doorhead with standard casings



cm 11,5

Capitello Quadrato con coprifili mod. Bastoncino rigato  
Square doorhead with casings mod. Striped strip



cm 11,5

Capitello Timpano interrotto - coprifili mod. Mensola liscia  
Broken gable doorhead with casings mod. Smooth corbel



cm 11,5

Capitello Timpano con coprifili mod. Mensola rigata  
Gable doorhead with casings mod. Striped corbel



cm 11,5

Capitello Lineare con coprifili mod. Bastoncino rigato  
Flat doorhead with casings mod. Striped strip



*Intarsio*





# Intarsio

Lasciare un segno, giocare con la materia, esaltandola, grazie a un lavoro artigianale raffinato e di altissima fattura.

Il prezioso intarsio in legno di rosa bordato di ebano, insieme alla finitura anticata, conferiscono alla porta un fascino antico. Classico che apre spazi a ogni personalità.

Leaving its mark, playing with materials, enhancing them through refined and highly skilled craftsmanship.

The rich inlay in ebony-bordered rosewood, along with aged finishing, bestows an antique charm on the door.

A classical style which opens spaces to any personality.



cod. 5-30 Alder anticato noce  
chiaro - capitello timpano  
interrotto - coprifili mod.  
bastoncino liscio e zoccolino.

code 5-30 Alder stained antique  
light walnut - Broken gable  
doorhead with casings mod.  
Smooth strip and plinth.

# Intarsio

legnoform





cod. 8R-32 Alder anticato noce chiaro, porta doppio battente con capitello lineare con rosette - coprifili standard.

code 8R-32 Alder stained antique light walnut, double-leaf door with Flat doorhead with turned blocks - standard casings.

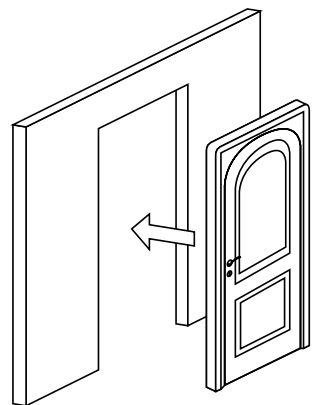

cod. 8R-14 Alder anticato noce chiaro - capitello lineare con rosette - coprifili standard.

code 8R-14 Alder stained antique light walnut - Flat doorhead with turned blocks - standard casings.

*Intarsio*

**legnoform**





cod. 3-11 Alder anticato noce  
chiaro - capitello centinato  
coprifili standard.

code 3-11 Alder stained antique  
light walnut - Bowed doorhead  
standard casings.



cod. 6-17 Alder anticato noce  
chiaro - capitello centinato  
coprifili standard.

code 6-17 Alder stained antique  
light walnut - Bowed doorhead  
standard casings.

*Intarsio*

**legnoform**





cod. 5-32 Alder anticato noce chiaro - capitello lineare - coprifili standard.  
code 5-32 Alder stained antique light walnut - Flat doorhead - standard casings.

*Intarsio*



Raffinato lavoro artigianale esaltato dall'intarsio in legno di rosa bordato d'ebano.

Refined craftsmanship enhanced by the ebony bordered rosewood inlay.





cod. 2-30 Alder anticato noce chiaro, porta doppio battente con cristalli legati ottone - capitello lineare con rosette, coprifili standard.

code 2-30 Alder stained antique light walnut, double-leaf door with brass beading glass - Flat doorhead with turned blocks, standard casings.



cod. 6-14 Alder anticato noce chiaro - capitello lineare con rosette, coprifili standard.

code 6-14 Alder stained antique light walnut - Flat doorhead with turned blocks, standard casings.



cod. 2-14 Alder anticato noce chiaro - capitello timpano, coprifili standard.

code 2-14 Alder stained antique light walnut - Gable doorhead, standard casings.

*Intarsio*

**legnoform**





cod. 5-30 Alder anticato noce scuro - capitello timpano interrotto, coprifili standard.

code 5-30 Alder stained antique dark walnut - Broken gable doorhead, standard casings.



cod. 5-31 Alder anticato noce scuro coprifili standard.

code 5-31 Alder stained antique dark walnut standard casings.

*Intarsio*

**legnoform**



# Le Soluzioni The Solutions

Immagina la porta dei tuoi desideri. Immaginala in casa tua, in un ambiente dove vivere una quotidianità piacevole, appagante, di stile. E immaginala esattamente come vuoi, perché qualunque sia la sua forma, possiamo realizzarla. Grazie alla maestria artigiana Legnoform, sono disponibili soluzioni speciali che consentono di realizzare ogni tua esigenza, con interventi unici realmente a misura di desiderio. Il tuo.

Imagine the door of your wish. Imagine it in your own home, a surrounding in which you can live a gratifying, pleasant and stylish everyday life. And imagine it exactly as you wish and with whatever shape, we can produce it. Legnoform's masterful craftsmanship will allow you to have special solutions uniquely tailored to a wish – your very own.

Alcuni esempi di soluzioni speciali  
Some examples of special solutions



Sopraluce con battente  
Transom with doorleaf

Fianco-luce e sopraluce  
Sidelight with transom window

Doppia asimmetrica  
Asymmetrical double door



Soluzione porta cod. 2-13 in Alder anticato noce chiaro con sopraluce con montanti perimetrali; cristalli doppio legato ottone; coprifili standard.  
Door solution code 2-13 in Alder stained antique light walnut with transom window with perimeter uprights; glass with double brass beading; standard casings.

# Intarsio

legnoform



# Intarsio

Porte in legno massello di Nocino Americano - Alder con intarsio in legno di rosa bordato d'ebano. Ogni modello è disponibile a 2 battenti e predisposto per vetro. Coprifili standard a 45°.

Solid wood Alder doors with ebony bordered rosewood inlay. Each model is available in the double-door version and can be fitted with glass. Standard 45° casings.

## I Modelli - The Models

La lavorazione Intarsio è realizzabile su tutte le Serie Legnoform ad eccezione delle Serie 100, 400, 700, 800 e 900.

The "Intarsio" finish is available on all Legnoform's Series with the exception of Series 100, 400, 700, 800 and 900.

## Le Finiture Legno - The Wood Finishes



Alder anticato noce chiaro.  
Intarsio in legno di rosa bordato d'ebano  
Alder stained antique light walnut.  
Inlay in ebony bordered rosewood

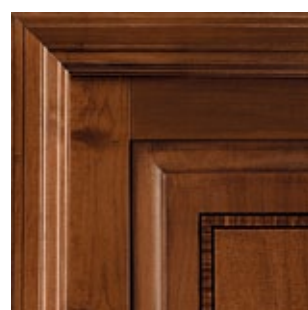

Alder anticato noce scuro.  
Intarsio in legno di rosa bordato d'ebano  
Alder stained antique dark walnut.  
Inlay in ebony bordered rosewood

## I Cristalli - The Glass

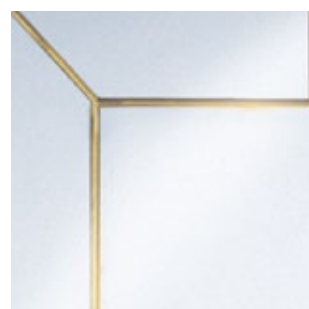

Legato ottone satinato bianco  
bisello lucido  
White satin - clear bevelled with  
brass beading



Doppio legato ottone satinato  
bianco/bronzo  
Satin white/bronze with  
double antique brass beading

## Le Cerniere - The Hinges

Cerniera in Stile,  
a pomella in ottone  
Old fashioned pintel  
hinge in brass



Finitura ottone  
satinato  
Mat brass finish

## Capitelli e coprifili - Doorheads and casings

Le porte Intarsio vengono fornite complete di coprifili standard a 45°. Capitelli e coprifili speciali disponibili a richiesta. Vedi anche approfondimento Sezione Capitelli pag. 370.

The Intarsio doors are supplied with standard 45° casings. Doorheads and special casings available upon request. See also the detailed section of doorheads and casings at page 370.

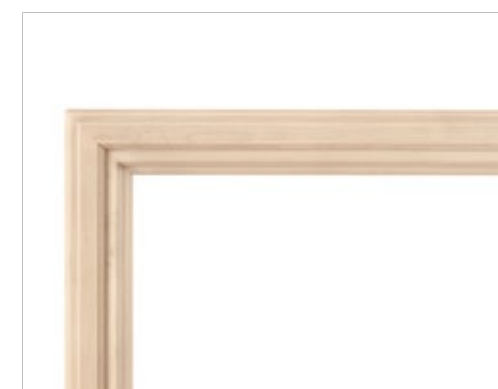

cm 6,4  
Coprifili standard  
Standard casings



Capitello Lineare con coprifili standard  
Flat doorhead with standard casings



Capitello Lineare con rosette con coprifili standard  
Flat doorhead with turned blocks and standard casings



Capitello Centinato con coprifili standard  
Bowed doorhead with standard casings



Capitello a Timpano con coprifili standard  
Gable doorhead with standard casings



cm 11,5  
Capitello Quadrato con coprifili mod. Bastoncino rigato  
Square doorhead with casings mod. Striped strip



cm 11,5  
Capitello Timpano interrotto - coprifili mod. Mensola liscia  
Broken gable doorhead with casings mod. Smooth corbel



cm 11,5  
Capitello Timpano con coprifili mod. Mensola rigata  
Gable doorhead with casings mod. Striped corbel



cm 11,5  
Capitello Lineare con coprifili mod. Bastoncino rigato  
Flat doorhead with casings mod. Striped strip





*Le Radiche*



# Le Radiche

Il prestigio nel prestigio. Una cornice che dà più luce a una meravigliosa tela. Il pannello in massello viene impreziosito dalla radica, con una lavorazione pregiata che sovrappone materiali, esaltandoli. Eleganza formale, coniugata al valore imprescindibile della materia.

Prestige within prestige. A frame that lightens up a magnificent painting. The solid wood panel is enriched by the briar-wood through a rich process which enhances the materials by overlapping them. Formal elegance married up with the inviolate value of material.

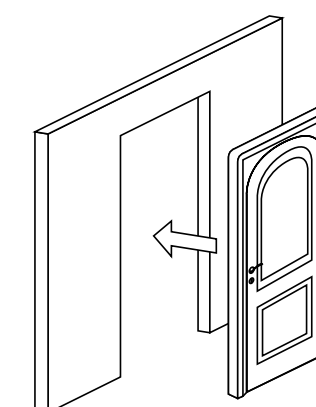
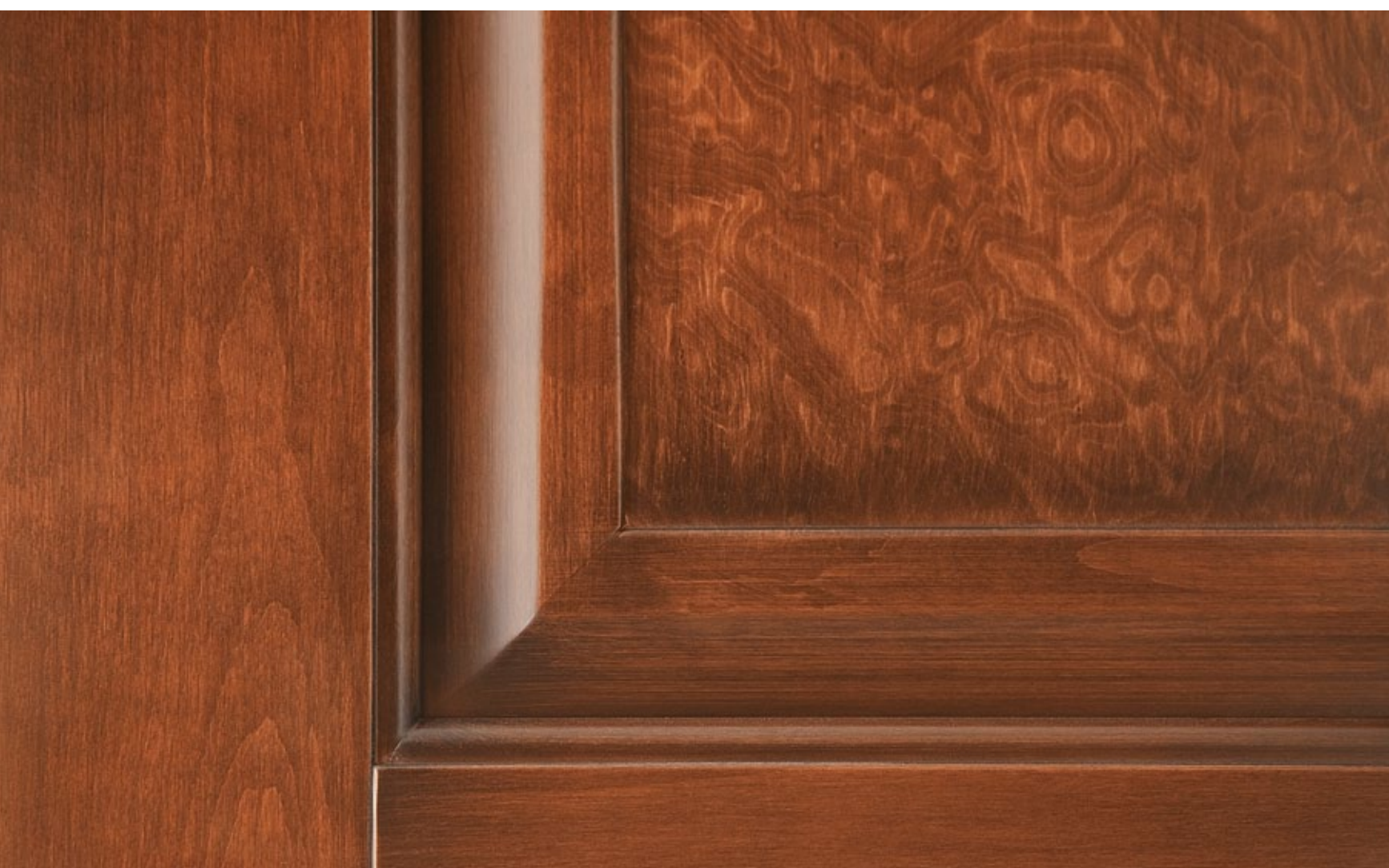

cod. 8R-14 Alder anticato  
mogano - capitello lineare con  
rosette - coprifili standard.

code 8R-14 Alder stained antique  
mahogany - Flat doorhead with  
turned blocks - standard casings.

# Le Radiche

legnoform





Porte in legno massello di Alder con pannelli in radica disponibili in tre finiture: anticato mogano, anticato noce chiaro, anticato noce scuro.

Solid wood Alder doors with briar wood panels available in three finishes: antique mahogany, antique light walnut, antique dark walnut.



cod. 8R-11 Alder anticato mogano - capitello lineare con rosette - coprifili standard.

code 8R-11 Alder stained antique mahogany - Flat doorhead with turned blocks - standard casings.



cod. 6-14 Alder anticato mogano capitello centinato coprifili standard.

code 6-14 Alder stained antique mahogany - Bowed doorhead standard casings.



Le Radiche

legnoform



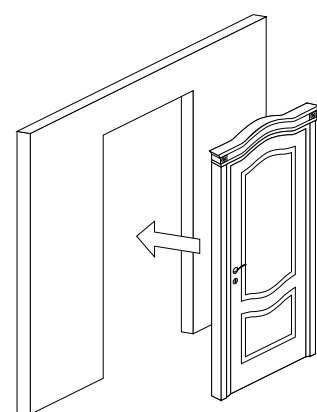

cod. 7R-17 Alder anticato noce  
chiaro - capitello 700R  
coprifili lisci.

code 7R-17 Alder stained antique  
light walnut - 700 R doorhead  
smooth casings.



cod. 7R-11 Alder anticato noce  
chiaro - capitello 700R  
coprifili lisci.

code 7R-11 Alder stained antique  
light walnut - 700 R doorhead  
smooth casings.



**legnoform**

*Le Radiche*





cod. 7-11 Alder anticato noce scuro - capitello lineare con rosette - coprifili standard.

code 7-11 Alder stained antique dark walnut - Flat doorhead with turned blocks - standard casings.



cod. 3-14 Alder anticato noce scuro - capitello centinato - coprifili standard.

code 3-14 Alder stained antique dark walnut - Bowed doorhead - standard casings.



cod. 2-14 Alder anticato noce scuro - capitello timpano coprifili standard.

code 2-14 Alder stained antique dark walnut - Gable doorhead - standard casings.

*Le Radiche*

**legnoform**



# Le Soluzioni *The Solutions*

Immagina la porta dei tuoi desideri. Immaginala in casa tua, in un ambiente dove vivere una quotidianità piacevole, appagante, di stile. E immaginala esattamente come vuoi, perché qualunque sia la sua forma, possiamo realizzarla. Grazie alla maestria artigiana Legnoform, sono disponibili soluzioni speciali che consentono di realizzare ogni tua esigenza, con interventi unici realmente a misura di desiderio. Il tuo.

Imagine the door of your wish. Imagine it in your own home, a surrounding in which you can live a gratifying, pleasant and stylish everyday life. And imagine it exactly as you wish and with whatever shape, we can produce it. Legnoform's masterful craftsmanship will allow you to have special solutions uniquely tailored to a wish – your very own.

Alcuni esempi di soluzioni speciali - Some examples of special solutions

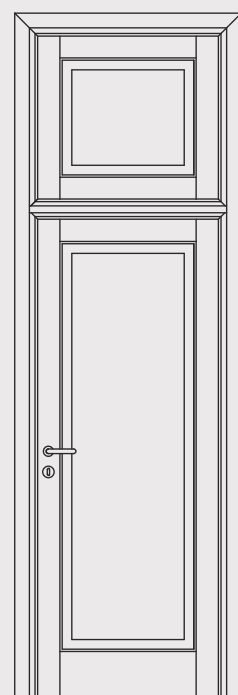

Sopraluce con battente  
Transom with doorleaf

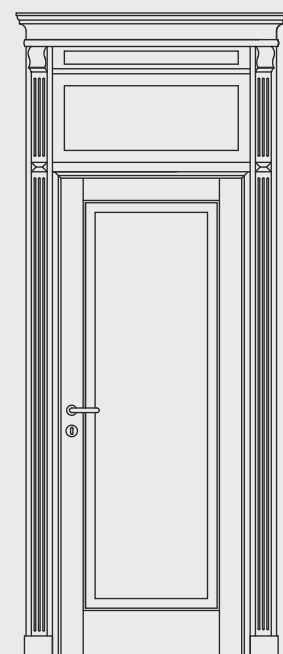

Chiambrana  
"Chiambrana"

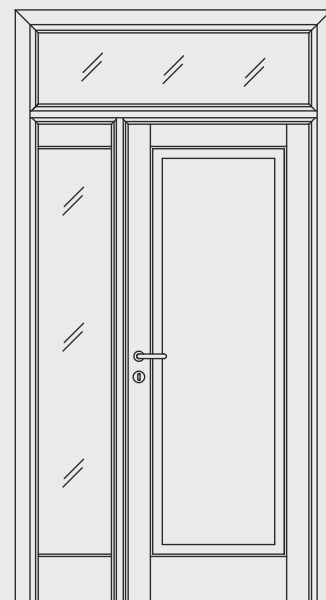

Fianco-luce e sopraluce  
Sidelight with transom window

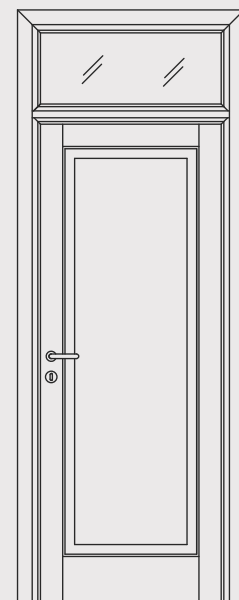

Sopraluce a vetro  
Transom window

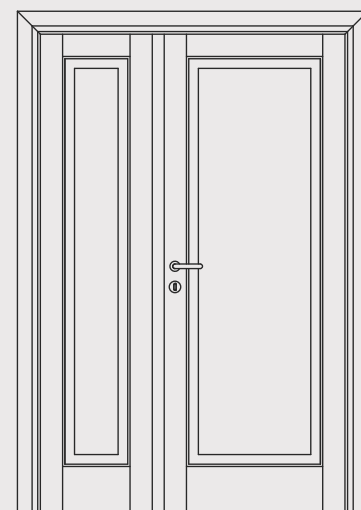

Doppia asimmetrica  
Asymmetrical double door

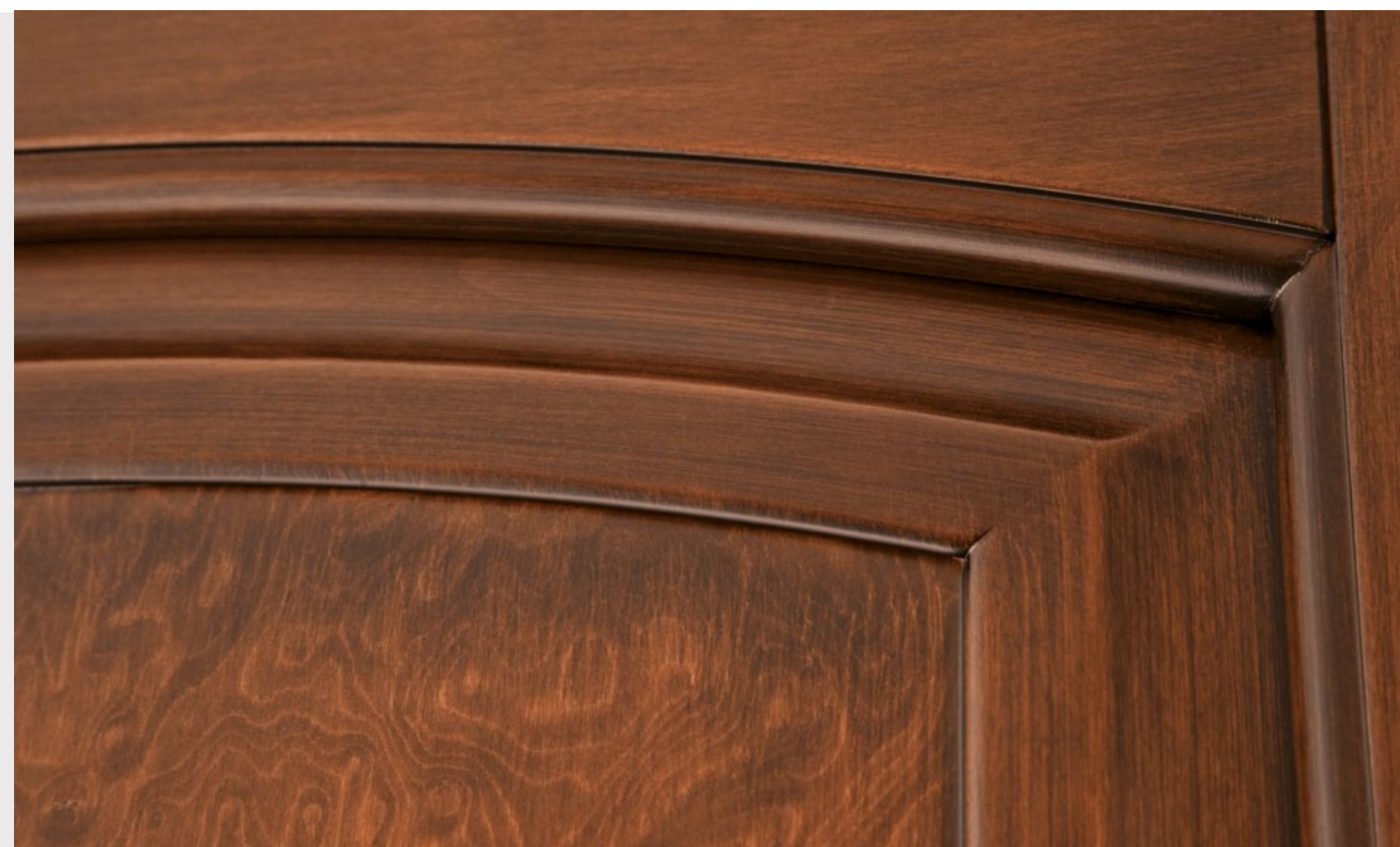

# Le Radiche



# Le Radiche

Porte in legno massello di Nocino Americano - Alder con pannelli in radica. Ogni modello è disponibile a 2 battenti e predisposto per vetro. Coprifili standard con taglio a 45°.

Solid wood Alder doors with briar wood panels. Each model is available in the double-door version and can be fitted with glass. Standard 45° casings.

## I Modelli - The Models

La lavorazione Le Radiche è realizzabile su tutte le Serie Legnoform, ad eccezione delle Serie 100, 400, 500, 800 e 900.

The "Le Radiche" finish is available on all Legnoform's Series, with the exception of Series 100, 400, 500, 800 and 900.

## Le Finiture Legno - The Wood Finishes

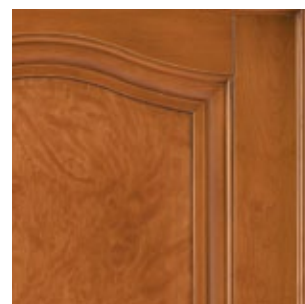

Alder anticato noce chiaro  
Alder stained antique light walnut

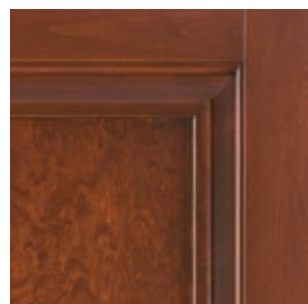

Alder anticato noce scuro  
Alder stained antique dark walnut

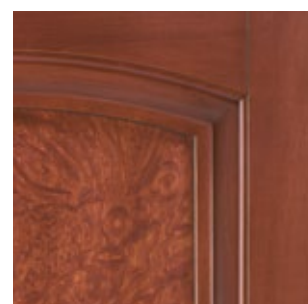

Alder anticato mogano  
Alder stained antique mahogany

## I Cristalli - The Glass



Legato ottone satinato bianco bisello lucido  
White satin - clear bevelled with brass beading



Doppio legato ottone satinato bianco/bronzo  
Satin white/bronze with double antique brass beading

## Le Cerniere - The Hinges

Cerniera in Stile, a pomella, in ottone  
Old fashioned pintel hinge, brass



Finitura ottone satinato  
Matt brass finish

## Capitelli e coprifili - Doorheads and casings

Le porte Le Radiche vengono fornite complete di coprifili standard a 45°. Capitelli e coprifili speciali disponibili a richiesta. Vedi anche approfondimento Sezione Capitelli pag. 370.

The Le Radiche doors are supplied with standard 45° casings. Doorheads and special casings available upon request. See also the detailed section of doorheads and casings at page 370.

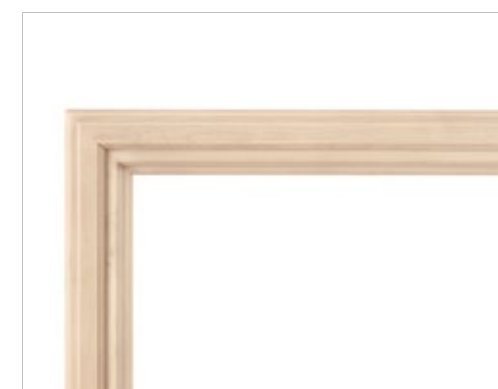

cm 6,4  
Coprifili standard  
Standard casings



Capitello Lineare con coprifili standard  
Flat doorhead with standard casings



Capitello Lineare con rosette con coprifili standard  
Flat doorhead with turned blocks and standard casings



Capitello Centinato con coprifili standard  
Bowed doorhead with standard casings



Capitello a Timpano con coprifili standard  
Gable doorhead with standard casings

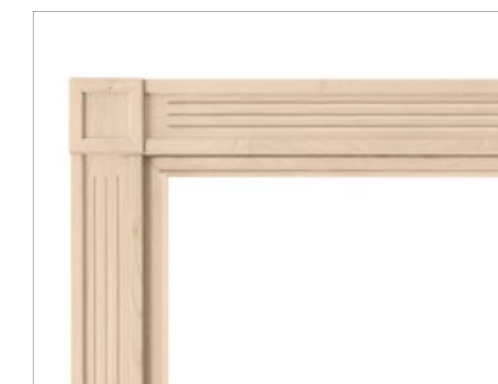

cm 11,5  
Capitello Quadrato con coprifili mod. Bastoncino rigato  
Square doorhead with casings mod. Striped strip



cm 11,5  
Capitello Timpano interrotto - coprifili mod. Mensola liscia  
Broken gable doorhead with casings mod. Smooth corbel



cm 11,5  
Capitello Timpano con coprifili mod. Mensola rigata  
Gable doorhead with casings mod. Striped corbel



cm 11,5  
Capitello Lineare con coprifili mod. Bastoncino rigato  
Flat doorhead with casings mod. Striped strip





Veneziana pag. 110

I Laccati pag. 140

Pergamenata pag. 158

Decapata pag. 170

Preziose finiture laccate che rendono ogni porta un piccolo capolavoro capace di adattarsi ad ogni contesto, antico o moderno.

Precious lacquered finishes that make every single door a little masterpiece suited for any antique or modern environment.





Veneziana



# Veneziana

Una delle massime espressioni della creatività e dello stile Legnoform. Un autentico marchio di fabbrica, fiore all'occhiello di un'artigianalità preziosa, sapiente, che parla di cultura del legno. A partire dalla laccatura avorio, eseguita esclusivamente a pennello con passaggi che disegnano cromie irripetibili, fino all'applicazione di vernice acrilica trasparente, un elogio all'arte sopraffina del creare materia che resta.

One of Legnoform's greatest displays of creativity and style. A real trade mark, the *crème de la crème* of rich and skilful craftsmanship which oozes wood culture.

Starting with ivory lacquering, carried out solely by brush strokes that create unrepeatable tone finishes, and finishing off with the application of transparent acrylic varnish, in honour of the masterly art of creating everlasting results.



cod. 1-35 Alder finitura  
Veneziana - coprifili lisci.

code 1-35 Alder Veneziana finish  
smooth casings.

# Veneziana

legnoform





cod. 2-11 Alder finitura Veneziana  
coprifili standard.

code 2-11 Alder Veneziana finish  
standard casings.



cod. 2-14 Alder finitura Veneziana - capitello  
timpano coprifili standard.

code 2-14 Alder Veneziana finish - Gable  
doorhead with standard casings.



cod. 5-30 Alder finitura  
Veneziana - capitello timpano  
interrotto - coprifili standard.

code 5-30 Alder Veneziana finish  
Broken gable doorhead with  
standard casings.

# Veneziana

legnoform





cod. 5-60 Alder finitura  
Veneziana - coprifili standard.  
code 5-60 Alder Veneziana finish  
standard casings.



cod. 6-17 Alder finitura  
Veneziana - capitello centinato  
coprifili standard.

code 6-17 Alder Veneziana finish  
Bowed doorhead with standard  
casings.

# Veneziana

legnoform





Veneziana





cod. 6-14 Alder finitura  
Veneziana - capitello centinato  
coprifili standard.

code 6-14 Alder Veneziana finish  
Bowed doorhead with standard  
casings.

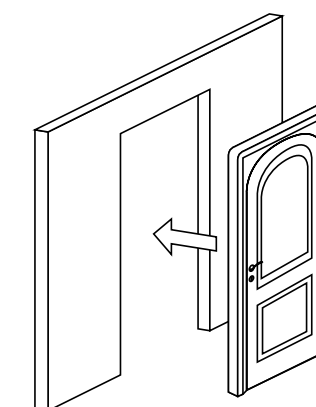

cod. 8R-13 Alder finitura  
Veneziana - cristallo legato  
ottone - capitello centinato  
coprifili standard.

code 8R-13 Alder Veneziana finish  
brass beading glass - Bowed  
doorhead with standard casings.

# Veneziana

legnoform



# Profilo oro Gold profile

La nobiltà antica dell'oro, il fascino di una lavorazione preziosa che esalta le qualità artigianali Legnoform.

Una contaminazione che eleva, infonde prestigio, incastona un filo di emozione nella solidità della tradizione.

The old nobility of gold, the charm of rich workmanship which celebrates Legnoform's craftsmanship.

This has a magnificent knock-on effect, enhancing the glamour, setting a thread of emotion in the soundness of tradition.



cod. 5-30 Alder finitura Veneziana con profilo oro - capitello timpano con coprifili standard.  
code 5-30 Alder Veneziana finish with gold profiles - Gable doorhead with standard casings.

# Veneziana





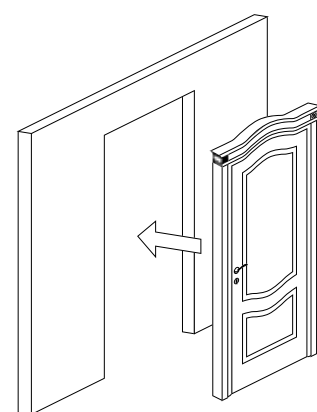

cod. 7R-17 Alder finitura  
Veneziana con profilo oro  
capitello 700R - coprifili lisci.

code 7R-17 Alder Veneziana finish  
with gold profiles - 700R doorhead  
with smooth casings.



cod. 8R-14 Alder finitura Veneziana con profilo oro  
capitello lineare con rosette - coprifili standard.

code 8R-14 Alder Veneziana finish with gold profiles  
Flat doorhead with turned blocks and standard casings.



cod. 6-17 Alder finitura Veneziana con profilo oro  
capitello centinato - coprifili standard.

code 6-17 Alder Veneziana finish with gold profiles  
Bowed doorhead with standard casings.

# Veneziana



# I Decori Decors

Classicismo, reinterpretazioni di stile che affondano le proprie radici nell'arte che ha costruito modelli di riferimento.

La finitura Veneziana si arricchisce di decori straordinari nella loro semplice forza formale, dispensatori inconsapevoli di una chiave di lettura senza confine.

Classicism, new interpretations of a style rooted in the art that has created reference models.

The Veneziana finish is enriched by fine ornamental decors, magnificent in their formal simplicity.

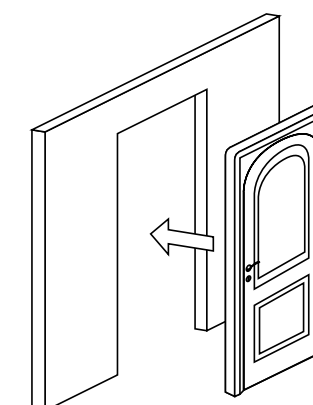

cod. 8R-14 Alder finitura Veneziana con decoro Filetti capitello lineare con rosette coprifili standard.

code 8R-14 Alder Veneziana finish with "Filetti" decor - Flat doorhead with turned blocks and standard casings.

# Veneziana

legnoform





cod. 2-14 Alder finitura Veneziana con decoro Filetti - capitello timpano - coprifili standard.

code 2-14 Alder Veneziana finish with "Filetti" decor - Gable doorhead with standard casings.



cod. 5-30 Alder finitura Veneziana con decoro Filetti capitello timpano interrotto - coprifili standard.

code 5-30 Alder Veneziana finish with "Filetti" decor Broken gable doorhead with standard casings.

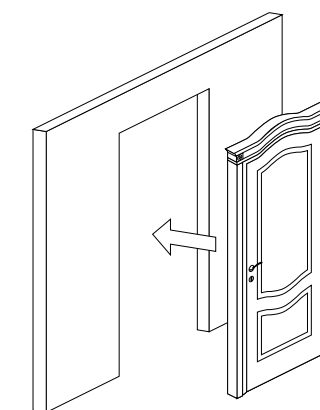

cod. 7R-17 Alder finitura Veneziana con decoro Filetti capitello 700R - coprifili lisci.

code 7R-17 Alder Veneziana finish with "Filetti" decor - 700R doorhead with smooth casings.

# Veneziana

legnoform





I Decori Decors



cod. 7-11 Alder finitura  
Veneziana con decoro  
Neoclassico - capitello lineare  
con rosette - coprifili standard.

code 7-11 Alder Veneziana finish  
with Neoclassical decor - Flat  
doorhead with turned blocks and  
standard casings.

legnoform



# Piattabande Platbands

La finitura Veneziana si arricchisce di un tocco di cromia distintiva, con l'applicazione di colore sulla piattabanda del pannello. La vernice acrilica trasparente, applicata al termine della lavorazione, protegge l'unicità della laccatura.

The Veneziana finish is enriched by a touch of distinctive tone by applying colour on the panel's platband.

The transparent acrylic varnish, applied at the end of the process, will protect the uniqueness of the lacquering.



# Veneziana

cod. 5-32 Alder finitura Veneziana con piattabanda azzurra - capitello lineare - coprifili standard.  
code 5-32 Alder Veneziana finish with light blue platband - Flat doorhead with standard casings.





cod. 6-14 Alder finitura Veneziana con piattabanda azzurra capitello centinato - coprifili standard.

code 6-14 Alder Veneziana finish with light blue platband - Bowed doorhead with standard casings.



cod. 2-14 Alder finitura Veneziana con piattabanda ocra capitello timpano - coprifili standard.

code 2-14 Alder Veneziana finish with ochre platband - Gable doorhead with standard casings.



cod. 5-30 Alder finitura Veneziana con piattabanda verde capitello timpano interrotto coprifili standard.

code 5-30 Alder Veneziana finish with green platband - Broken gable doorhead with standard casings.

# Veneziana

legnoform



# Le Soluzioni

## The Solutions

Immagina la porta dei tuoi desideri. Immaginala in casa tua, in un ambiente dove vivere una quotidianità piacevole, appagante, di stile. E immaginala esattamente come vuoi, perché qualunque sia la sua forma, possiamo realizzarla. Grazie alla maestria artigiana Legnoform, sono disponibili soluzioni speciali che consentono di realizzare ogni tua esigenza, con interventi unici realmente a misura di desiderio. Il tuo.

Imagine the door of your wish. Imagine it in your own home, a surrounding in which you can live a gratifying, pleasant and stylish everyday life. And imagine it exactly as you wish and with whatever shape, we can produce it. Legnoform's masterful craftsmanship will allow you to have special solutions uniquely tailored to a wish – your very own.

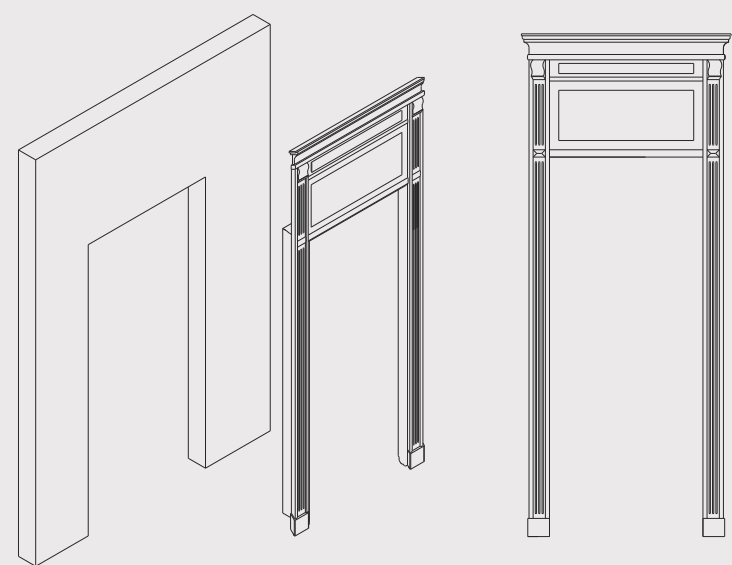

Le Chiambrane Legnoform, soluzioni dal grande impatto visivo che permettono di essere installate senza apporre alcuna modifica muraria. Disponibili su tutti i modelli Legnoform.

“Le Chiambrane” Legnoform, exceptionally eye-catching solutions that can be installed without changing the wall openings. Available on all Legnoform's models.



Soluzione porta cod. 2-14 in Alder finitura Veneziana con Chiambrana decoro Neoclassico con capitello - coprifili mod. mensola liscia e zoccolino.

Door solution code 2-14 in Alder Veneziana finish with “Chiambrana” Neoclassical decor supplied with doorhead – casings mod. Smooth corbel and plinth.

# Veneziana

legnoform



# Veneziana

Porte in legno massello di Nocino Americano - Alder laccato Veneziana a pennello. Ogni modello è disponibile nella versione a 2 battenti e predisposto per vetro. Coprifili standard a 45°.

Solid wood Alder doors lacquered in the old Venetian type of brush finish. Each model is available in the double-door version and can be fitted with glass. Standard 45°.

## I Modelli - The Models

La finitura Veneziana è realizzabile su tutte le Serie Legnoform. The Veneziana finish is available on all Legnoform's Series.

## Le Finiture - The Finishes



Alder finitura Veneziana  
Alder Veneziana finish



Alder finitura Veneziana - profilo oro  
Alder Veneziana finish - gold profile

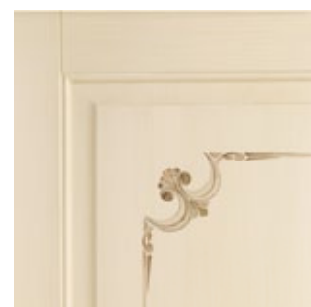

Alder finitura Veneziana - decoro Filetti  
Alder Veneziana finish - Filetti decor

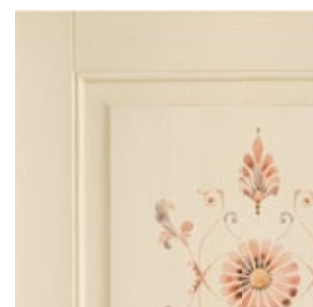

Alder finitura Veneziana decoro Neoclassico  
Alder Veneziana finish Neoclassical decor



Alder finitura Veneziana piattabanda verde  
Alder Veneziana finish green platband



Alder finitura Veneziana piattabanda azzurra  
Alder Veneziana finish light blue platband



Alder finitura Veneziana piattabanda ocra  
Alder Veneziana finish ochre platband

## I Cristalli - The Glass

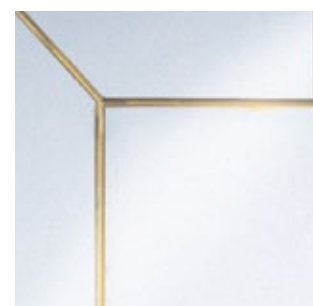

Legato ottone satinato bianco bisello lucido  
White satin - clear bevelled with brass beading



Doppio legato ottone satinato bianco/bronzo  
Satin white/bronze with double antique brass beading

## Le Cerniere - The Hinges

Cerniera in Stile, a pomella, in ottone o in ferro  
Old fashioned pintel hinge in brass or in iron



Finitura ottone satinato  
Mat brass finish



Finitura brunita  
Burnished finish

## Capitelli e coprifili - Doorheads and casings

Le porte Veneziana vengono fornite complete di coprifili standard a 45°. Capitelli e coprifili speciali disponibili a richiesta. Vedi anche approfondimento Sezione Capitelli pag. 370.

The Veneziana doors are supplied with standard 45° casings. Doorheads and special casings available upon request. See also the detailed section of doorheads and casings at page 370.

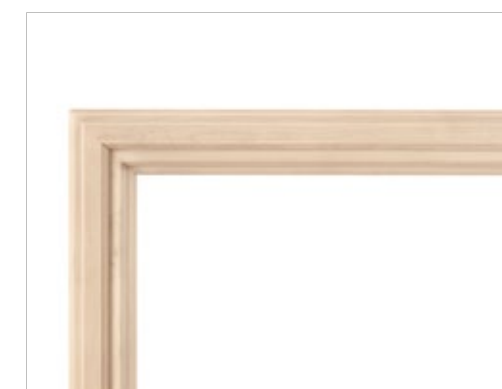

cm 6,4  
Coprifili standard  
Standard casings



Capitello Lineare con coprifili standard  
Flat doorhead with standard casings



Capitello Lineare con rosette con coprifili standard  
Flat doorhead with turned blocks and standard casings



Capitello Centinato con coprifili standard  
Bowed doorhead with standard casings



Capitello a Timpano con coprifili standard  
Gable doorhead with standard casings

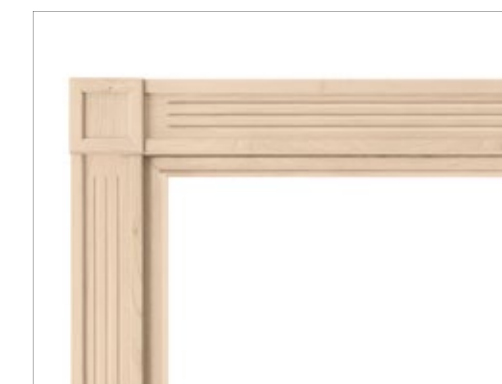

cm 11,5  
Capitello Quadrato con coprifili mod. Bastoncino rigato  
Square doorhead with casings mod. Striped strip



cm 11,5  
Capitello Timpano interrotto - coprifili mod. Mensola liscia  
Broken gable doorhead with casings mod. Smooth corbel



cm 11,5  
Capitello Timpano con coprifili mod. Mensola rigata  
Gable doorhead with casings mod. Striped corbel



cm 11,5  
Capitello Lineare con coprifili mod. Bastoncino rigato  
Flat doorhead with casings mod. Striped strip



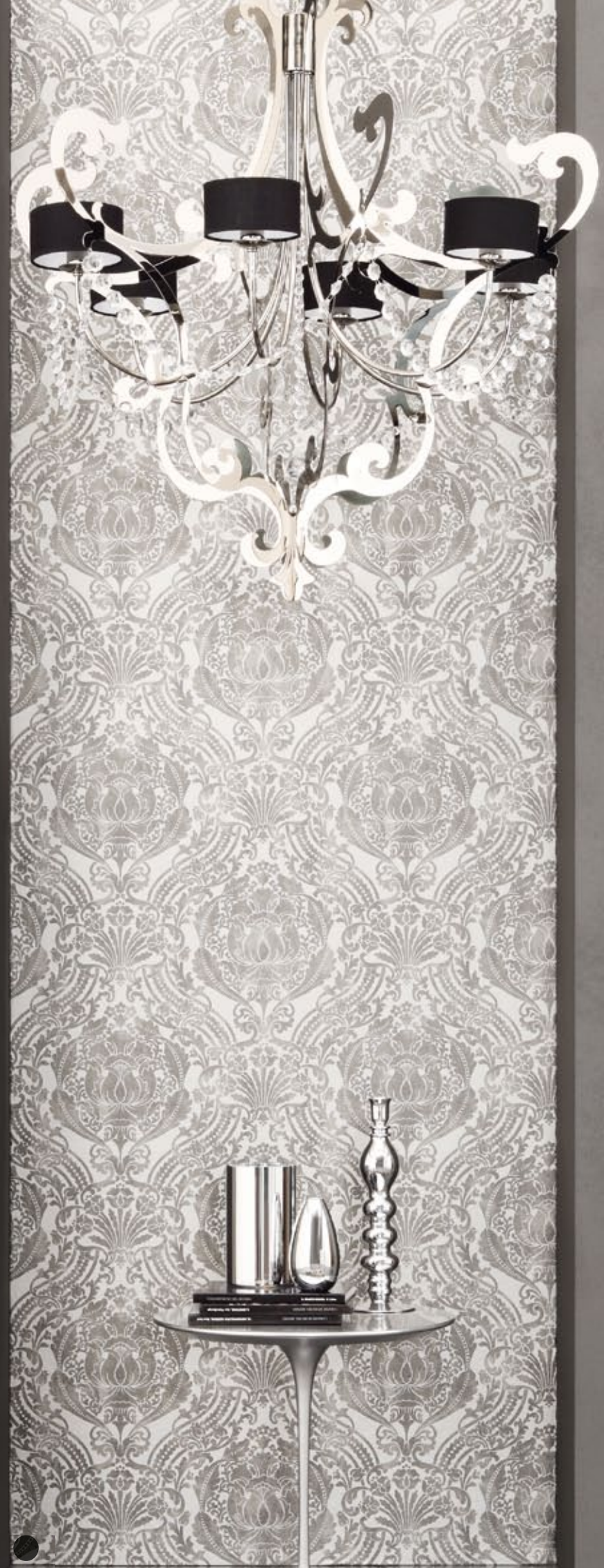

I Laccati



# I Laccati

Ogni porta Legnoform è un piccolo capolavoro che può essere cesellato intorno a ogni esigenza. E con diversi trattamenti: tra cui, la laccatura. Che rende tutte le soluzioni stilistiche preziose, le colloca al centro dell'impianto architettonico complessivo, dando e ricevendo importanza in un perfetto equilibrio. In ogni contesto, antico o moderno, rappresenta una diversa interpretazione di uno stile.

Every Legnoform door is a little masterpiece which can be sculpted around any requirements. And through various treatments, such as the lacquering which enriches any design, centring it in the architectural setting, giving and taking importance in perfect harmony. It represents a different interpretation of a style in any antique or modern environment.

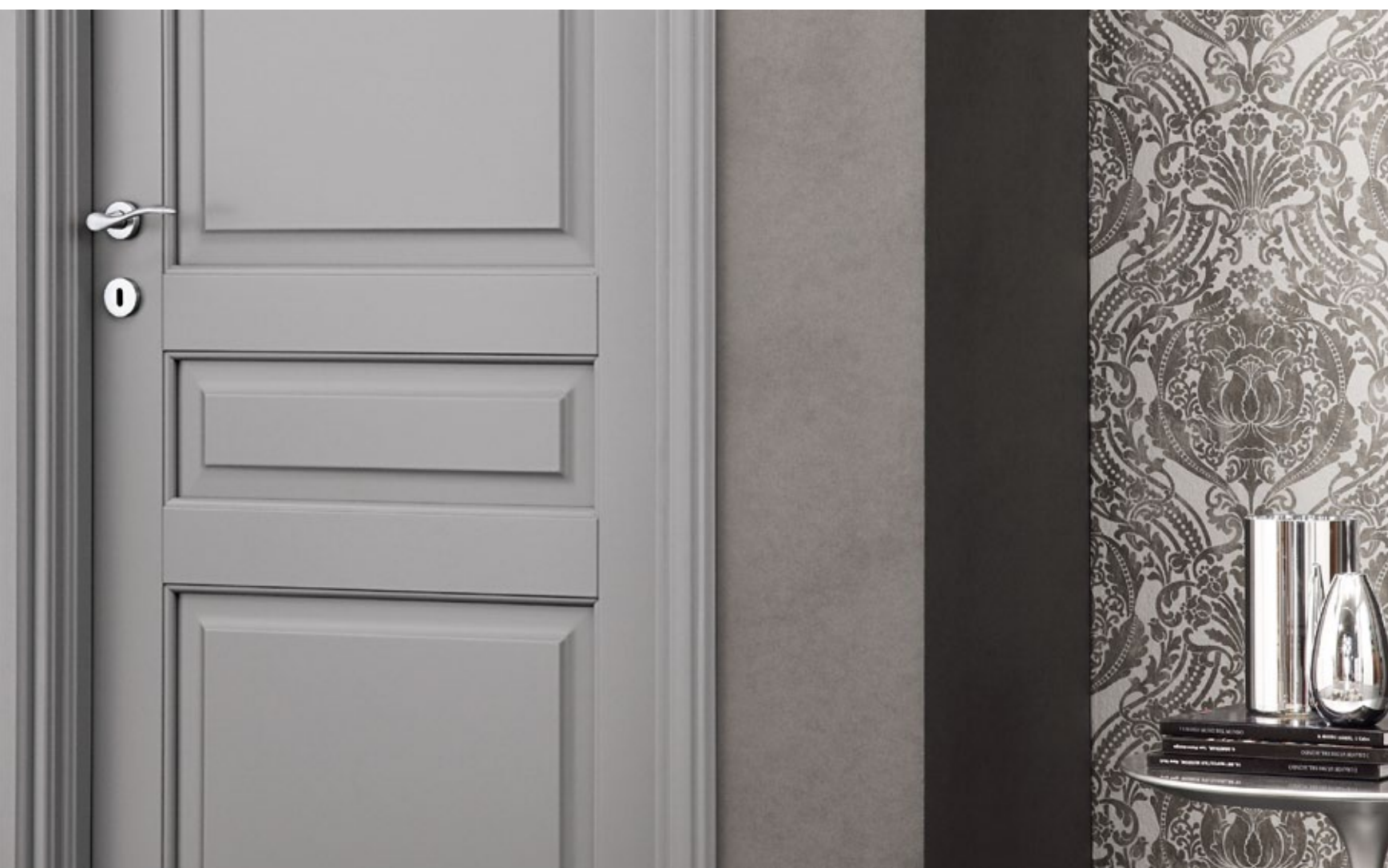

cod. 7R-17 Alder finitura laccato nero - capitello 700R - coprifili lisci.

code 7R-17 Alder black lacquered finish - 700R doorhead - smooth casings.

# I Laccati

legnoform





cod. 2-34 Alder finitura laccato bianco - porta doppio battente con cristalli satinati bianchi - bisello lucido - coprifili standard.

code 2-34 Alder white lacquered finish - double-leaf door with white satin, clear bevelled glass - standard casings.



cod. 2-11 Alder finitura laccato bianco coprifili standard.

code 2-11 Alder white lacquered finish standard casings.



cod. 3-19 Alder finitura laccato bianco - cristalli satinati bianchi, bisello lucido - coprifili standard.

code 3-19 Alder white lacquered finish, white satin clear bevelled glass - standard casings.

# I Laccati

legnoform





cod. 5-30 Alder finitura laccato  
grigio - capitello timpano  
interrotto - coprifili standard.

code 5-30 Alder grey lacquered  
finish - Broken gable doorhead  
standard casings.



cod. 5-31 Alder finitura laccato  
grigio - capitello lineare  
coprifili standard.

code 5-31 Alder grey lacquered  
finish - Flat doorhead - standard  
casings.

# I Laccati

legnoform





cod. 6-17 Alder finitura laccato crema - capitello centinato - coprifili standard.  
code 6-17 Alder cream lacquered finish - Bowed doorhead - standard casings.

# I Laccati



Equilibrio tra eleganza e stile.  
Un design raffinato che interpreta ogni ambiente diventando  
il centro in cui confluisce l'attenzione.

A balance of elegance and style. A refined design interpreting any  
ambience and becoming the centre of attention.





cod. 7-13 Alder finitura laccato  
salvia - cristallo legato ottone  
capitello lineare - coprifili  
standard.

code 7-13 Alder light green  
lacquered finish - brass beading  
glass - Flat doorhead - standard  
casings.



cod. 7-14 Alder finitura laccato  
salvia - capitello lineare  
coprifili standard.

code 7-14 Alder light green  
lacquered finish - Flat doorhead  
standard casings.

# I Laccati

legnoform





cod. 2-13 Alder finitura laccato  
corda - cristallo legato ottone  
coprifili standard.

code 2-13 Alder beige lacquered  
finish - brass beading glass  
standard casings.



cod. 2-14 Alder finitura laccato  
corda - capitello timpano  
interrotto - coprifili standard.

code 2-14 Alder beige lacquered  
finish - Broken gable doorhead  
standard casings.

# I Laccati

legnoform



# Le Soluzioni

## The Solutions

Immagina la porta dei tuoi desideri. Immaginala in casa tua, in un ambiente dove vivere una quotidianità piacevole, appagante, di stile. E immaginala esattamente come vuoi, perché qualunque sia la sua forma, possiamo realizzarla. Grazie alla maestria artigiana Legnoform, sono disponibili soluzioni speciali che consentono di realizzare ogni tua esigenza, con interventi unici realmente a misura di desiderio. Il tuo.

Imagine the door of your wish. Imagine it in your own home, a surrounding in which you can live a gratifying, pleasant and stylish everyday life. And imagine it exactly as you wish and with whatever shape, we can produce it. Legnoform's masterful craftsmanship will allow you to have special solutions uniquely tailored to a wish – your very own.

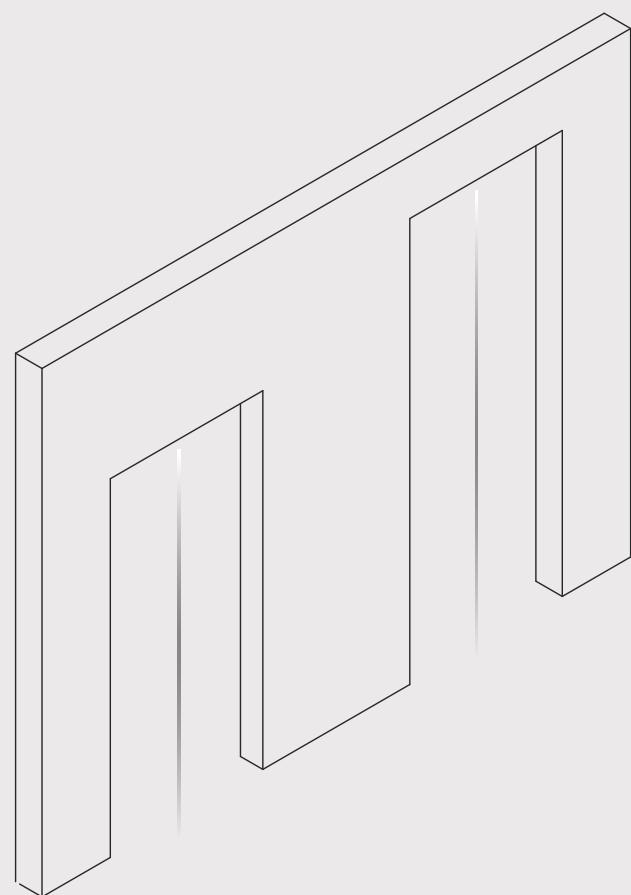

Alcuni esempi di soluzioni speciali  
Some examples of special solutions



Grazie alla sua grande maestria artigiana Legnoform è in grado di offrire porte realizzate su misura secondo le Vs. esigenze.

Thanks to its flexible manufacturing abilities legnoform can produce doors according to your measures and needs.



Porta fuori misura in altezza  
cod. 5-30 Alder finitura laccato  
grigio - capitello timpano  
interrotto - coprifili mod.  
bastoncino liscio e zoccolino.

Special Height door code 5-30 Alder  
grey lacquered finish - Broken  
gable doorhead - casings mod.  
Smooth strip and plinth.

# I Laccati

legnoform



# I Laccati

Porte in legno massello di Nocino Americano Alder, laccate. Ogni modello è disponibile nella versione a 2 battenti e predisposto per vetro. Coprifili standard a 45°.

Solid wood Alder lacquered doors. Each model is available in the double-door version and can be fitted with glass. Standard 45° casings.

## I Modelli - The Models

La finitura Laccata è realizzabile su tutte le Serie Legnoform. The Lacquered finish is available on all Legnoform's Series.

## Le Finiture - The Finishes

Porte laccate RAL su indicazione del Cliente. Doors lacquered on Customer's RAL number.

## I Cristalli - The Glass

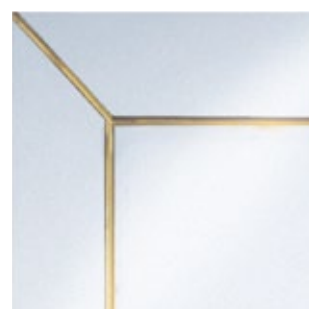

Legato ottone satinato bianco - bisello lucido  
White satin - clear bevelled with brass beading

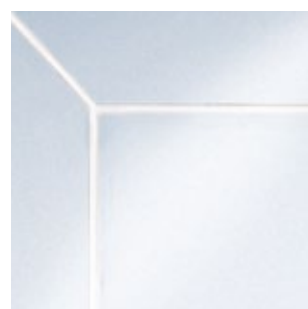

Inciso disegno legato, satinato bianco - bisello lucido  
Bevel detail like brass beading, white satin clear bevelled

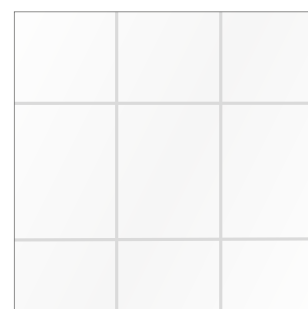

Inciso all'inglese, satinato bianco - bisello lucido  
Bevel detail section - white satin, clear bevelled

## Le Cerniere - The Hinges

Cerniera in Stile, a pomella, in ottone o in ferro  
Old fashioned pintel hinge in brass or in iron



Finitura ottone satinato  
Mat brass finish



Finitura brunita  
Burnished finish

Cerniera classica, a pomella, in ottone  
Classical pintel hinge in brass



Finitura ottone lucido o satinato  
Polished or mat brass finish



Finitura cromato lucido o satinato  
Polished or mat chrome finish

## Capitelli e coprifili - Doorheads and casings

Le porte Laccate vengono fornite complete di coprifili standard a 45°. Capitelli e coprifili speciali disponibili a richiesta. Vedi anche approfondimento Sezione Capitelli pag. 370.

The Lacquered doors are supplied with standard 45° casings. Doorheads and special casings available upon request. See also the detailed section of doorheads and casings at page 370.

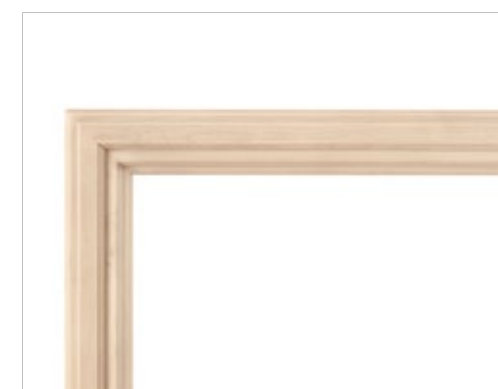

cm 6,4  
Coprifili standard  
Standard casings



Capitello Lineare con coprifili standard  
Flat doorhead with standard casings



Capitello Lineare con rosette con coprifili standard  
Flat doorhead with turned blocks and standard casings



Capitello Centinato con coprifili standard  
Bowed doorhead with standard casings



Capitello a Timpano con coprifili standard  
Gable doorhead with standard casings



cm 11,5  
Capitello Quadrato con coprifili mod. Bastoncino rigato  
Square doorhead with casings mod. Striped strip



cm 11,5  
Capitello Timpano interrotto - coprifili mod. Mensola liscia  
Broken gable doorhead with casings mod. Smooth corbel



cm 11,5  
Capitello Timpano con coprifili mod. Mensola rigata  
Gable doorhead with casings mod. Striped corbel



cm 11,5  
Capitello Lineare con coprifili mod. Bastoncino rigato  
Flat doorhead with casings mod. Striped strip





Pergamemata



# Pergamenata

Una storia che viene da lontano, che oltrepassa i secoli per arrivare fino al presente. Come una preziosa carta su cui vergare parole, la finitura Pergamenata comunica ricercatezza, manda un messaggio di stile e personale interpretazione dello spazio. Una prima mano di colore avorio, cui sovrapporre una seconda applicazione irregolare che crea effetti di contrastato invecchiamento naturale.

A story which started far away, and travelled down through the centuries to reach us in the present day. Just like the precious paper on which words are scripted, this Parchment finish conveys refinement, sends both a message of style as well as personal interpretation of space. An ivory undercoat is followed by a second irregular application which creates contrasting looks of natural ageing.



cod. 6-17 Alder finitura  
Pergamenata - capitello  
centinato - coprifili standard.

code 6-17 Alder Pergamenata  
finish - Bowed doorhead with  
standard casings.

# Pergamenata

legnoform





cod. 6-14 Alder finitura  
Pergamenata - coprifili  
standard.

code 6-14 Alder Pergamenata  
finish - standard casings.



cod. 5-32 Alder finitura  
Pergamenata - capitello lineare  
coprifili standard.

code 5-32 Alder Pergamenata  
finish - Flat doorhead with  
standard casings.

# Pergamenata

legnoform



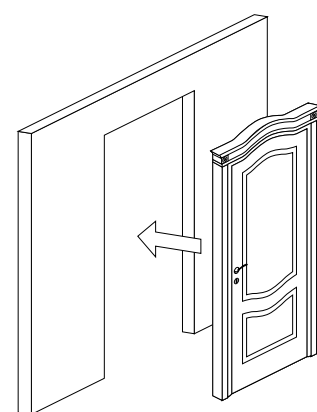

cod. 7R-17 Alder finitura  
Pergamenata - capitello 700R  
coprifili lisci.

code 7R-17 Alder Pergamenata  
finish - 700R doorhead with  
smooth casings.



cod. 7R-37 Alder finitura Pergamenata, porta doppio battente  
capitello 700R coprifili lisci.

code 7R-37 Alder Pergamenata finish, double-leaf door - 700R doorhead  
with smooth casings.

# Pergamenata

legnoform



# Le Soluzioni The Solutions

Immagina la porta dei tuoi desideri. Immaginala in casa tua, in un ambiente dove vivere una quotidianità piacevole, appagante, di stile. E immaginala esattamente come vuoi, perché qualunque sia la sua forma, possiamo realizzarla. Grazie alla maestria artigiana Legnoform, sono disponibili soluzioni speciali che consentono di realizzare ogni tua esigenza, con interventi unici realmente a misura di desiderio. Il tuo.

Imagine the door of your wish. Imagine it in your own home, a surrounding in which you can live a gratifying, pleasant and stylish everyday life. And imagine it exactly as you wish and with whatever shape, we can produce it. Legnoform's masterful craftsmanship will allow you to have special solutions uniquely tailored to a wish – your very own.



Alcuni esempi di soluzioni speciali - Some examples of special solutions

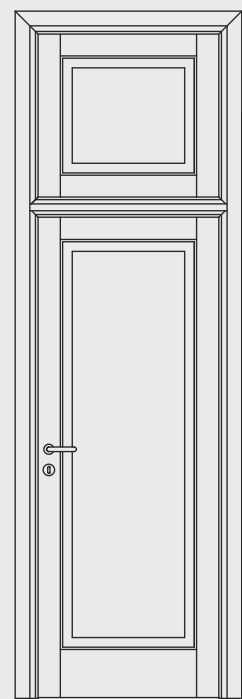

Sopraluce con battente  
Transom with doorleaf

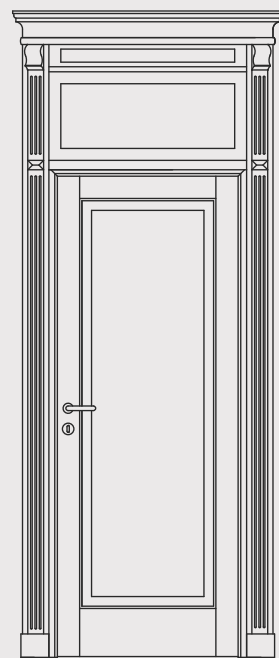

Chiambrana  
"Chiambrana"

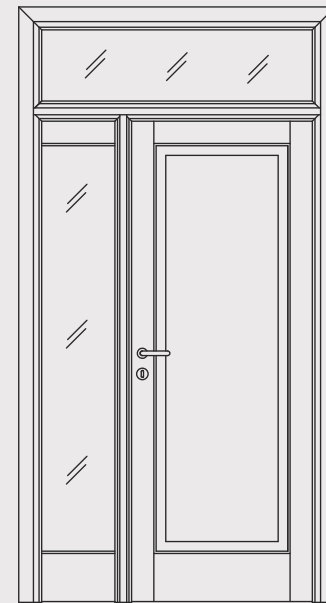

Fianco-luce e sopraluce  
Sidelight with transom window

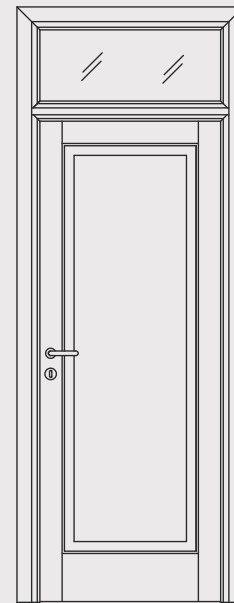

Sopraluce a vetro  
Transom window

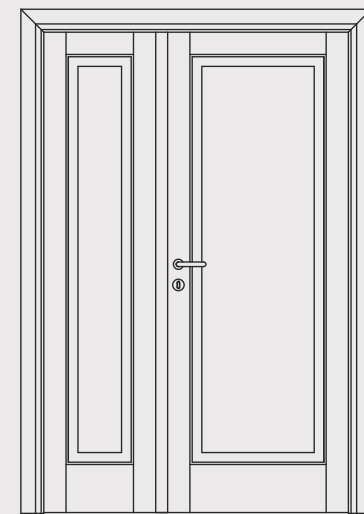

Doppia asimmetrica  
Asymmetrical double door





# Pergamenata

Porte in legno massello di Nocino Americano-Alder finitura Pergamenata. Ogni modello è disponibile nella versione a 2 battenti e predisposto per vetro. Coprifili standard a 45°.

Solid wood Alder doors Pergamenata finish. Each model is available in the double-door version and can be fitted with glass. Standard 45° casings.

## I Modelli - The Models

La finitura Pergamenata è realizzabile su tutte le Serie Legnoform.

The Pergamenata finish is available on all Legnoform's Series.

## Le Finiture - The Finishes



Alder finitura Pergamenata  
Alder Pergamenata finish

## I Cristalli - The Glass

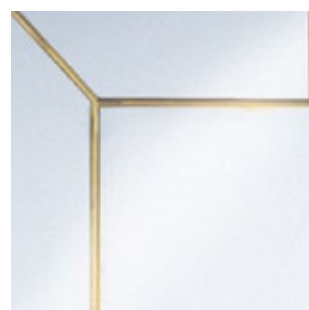

Legato ottone satinato bianco bisello lucido  
White satin - clear bevelled with brass beading



Doppio legato ottone satinato bianco/bronzo  
Satin white/bronze with double antique brass beading

## Le Cerniere - The Hinges

Cerniera in Stile, a pomella, in ottone o in ferro  
Old fashioned pintel hinge, in brass or in iron



Finitura ottone satinato  
Mat brass finish



Finitura brunita  
Burnished finish

## Capitelli e coprifili - Doorheads and casings

Le porte Pergamenata vengono fornite complete di coprifili standard a 45°. Capitelli e coprifili speciali disponibili a richiesta. Vedi anche approfondimento Sezione Capitelli pag. 370.

The Pergamenata doors are supplied with standard 45° casings. Doorheads and special casings available upon request. See also the detailed section of doorheads and casings at page 370.

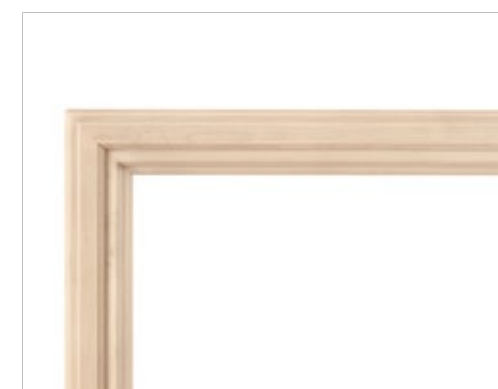

cm 6,4  
Coprifili standard  
Standard casings



Capitello Lineare con coprifili standard  
Flat doorhead with standard casings



Capitello Lineare con rosette con coprifili standard  
Flat doorhead with turned blocks and standard casings



Capitello Centinato con coprifili standard  
Bowed doorhead with standard casings



Capitello a Timpano con coprifili standard  
Gable doorhead with standard casings



cm 11,5  
Capitello Quadrato con coprifili mod. Bastoncino rigato  
Square doorhead with casings mod. Striped strip



cm 11,5  
Capitello Timpano interrotto - coprifili mod. Mensola liscia  
Broken gable doorhead with casings mod. Smooth corbel



cm 11,5  
Capitello Timpano con coprifili mod. Mensola rigata  
Gable doorhead with casings mod. Striped corbel



cm 11,5  
Capitello Lineare con coprifili mod. Bastoncino rigato  
Flat doorhead with casings mod. Striped strip





# Decapata





# Decapata

Venature che raccontano una storia, nodi che parlano di tempo, di nobiltà. La preziosità di un materiale lo si legge nella sua intensa natura, nell'architettura complessa del corpo stesso. Il colore lascia trasparire tutta la qualità del legno Massello, la finitura bianca semi trasparente è consumata sui bordi per conferire un aspetto elegantemente vissuto.

Woodgrain that tells a story, knotting that portray time and nobility. The richness of a material can be identified in its own intense nature, in the complex architecture of its own body. Colour lets all the quality of the solid wood gleam through, the half-transparent white finish is purposely worn out around the edges to give an elegantly aged look.

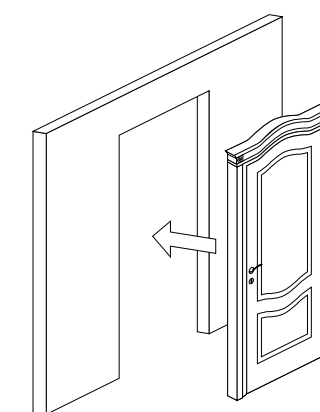

cod. 7R-17 Alder finitura  
Decapata - capitello 700R  
coprifili lisci.

code 7R-17 Alder Decapata finish  
700R doorhead - smooth casings.

# Decapata

legnoform





cod. 2-14 Alder finitura Decapata  
capitello timpano - coprifili  
standard.

code 2-14 Alder Decapata finish  
Gable doorhead - standard casings.



cod. 7-14 Alder finitura Decapata  
capitello lineare con rosette  
coprifili standard.

code 7-14 Alder Decapata finish  
Flat doorhead with turned blocks  
standard casings.

# Decapata

legnoform





cod. 9-14 Alder finitura Decapata  
coprifili standard.

code 9-14 Alder Decapata finish  
standard casings.



cod. 6-14 Rovere finitura Decapata - capitello  
centinato - coprifili standard.

code 6-14 Oak Decapata finish - Bowed doorhead  
standard casings.



cod. 3-14 Rovere finitura Decapata - capitello  
centinato - coprifili standard.

code 3-14 Oak Decapata finish - Bowed doorhead  
standard casings.

# Decapata





cod. 2-11 Rovere finitura  
Decapata - coprifili standard.  
code 2-11 Oak Decapata finish  
standard casings.



cod. 2-20 Rovere finitura  
Decapata - cristalli satinati  
bianchi, bisello lucido - coprifili  
standard.

code 2-20 Oak Decapata finish  
white satin, clear bevelled glass  
standard casings.

# Decapata

legnoform



# Le Soluzioni The Solutions

Immagina la porta dei tuoi desideri. Immaginala in casa tua, in un ambiente dove vivere una quotidianità piacevole, appagante, di stile. E immaginala esattamente come vuoi, perché qualunque sia la sua forma, possiamo realizzarla. Grazie alla maestria artigiana Legnoform, sono disponibili soluzioni speciali che consentono di realizzare ogni tua esigenza, con interventi unici realmente a misura di desiderio. Il tuo.

Imagine the door of your wish. Imagine it in your own home, a surrounding in which you can live a gratifying, pleasant and stylish everyday life. And imagine it exactly as you wish and with whatever shape, we can produce it. Legnoform's masterful craftsmanship will allow you to have special solutions uniquely tailored to a wish – your very own.

Alcuni esempi di soluzioni speciali - Some examples of special solutions

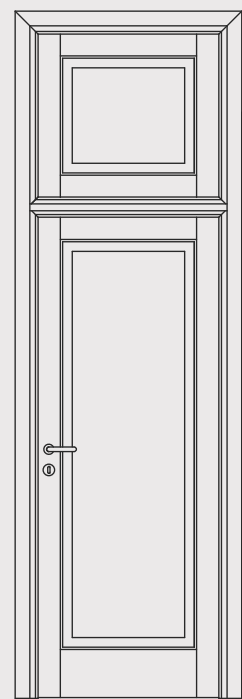

Sopraluce con battente  
Transom with doorleaf

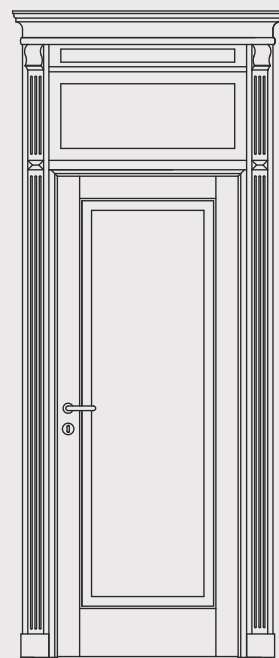

Chiambrana  
"Chiambrana"

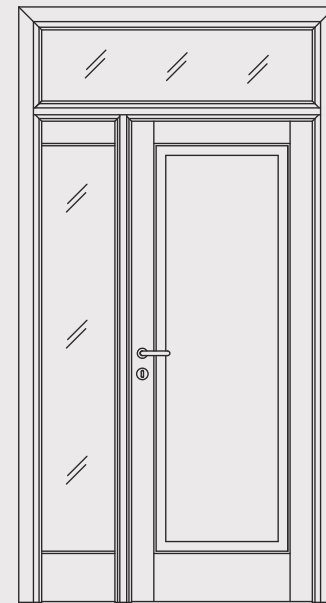

Fianco-luce e sopraluce  
Sidelight with transom window

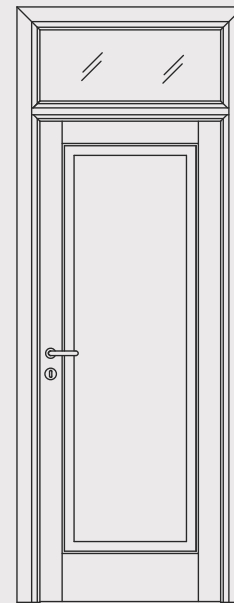

Sopraluce a vetro  
Transom window

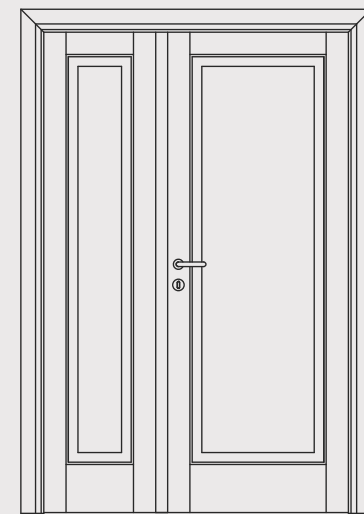

Doppia asimmetrica  
Asymmetrical double door

# Decapata



cod. 8R-14 Alder finitura  
Decapata porta con spessore  
muro intelaiato - coprifili con  
angoli arrotondati.

code 8R-14 Alder Decapata finish  
door with special frame - casings  
with rounded corners.

legnoform



# Decapata

Porte in legno massello di Nocino Americano-Alder e Rovere finitura Decapata. Ogni modello è disponibile nella versione a 2 battenti e predisposto per vetro. Coprifili standard a 45°.

Solid wood Alder and Oak doors in Decapata finish. Each model is available in the double version and can be fitted with glass. Standard 45° casings.

## I Modelli - The Models

La finitura Decapata è realizzabile su tutte le Serie Legnoform. The Decapata finish is available on all Legnoform's Series.

## Le Finiture Legno - The Wood Finishes



Alder finitura Decapata  
Alder Decapata finish



Rovere finitura Decapata  
Oak Decapata finish

## I Cristalli - The Glass

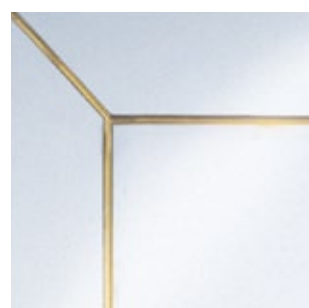

Legato ottone satinato  
bianco - bisello lucido  
White satin - clear bevelled with  
brass beading

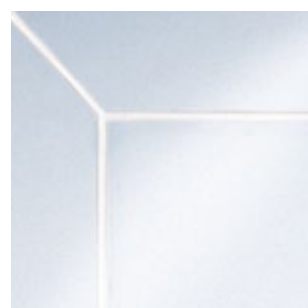

Inciso disegno legato, satinato  
bianco - bisello lucido  
Bevel detail like brass beading, white  
satin clear bevelled

## Le Cerniere - The Hinges

Cerniera in Stile,  
a pomella, in ottone  
o in ferro  
Old fashioned pintel  
hinge, in brass or in iron



Finitura ottone  
satinato  
Mat brass finish



Finitura brunita  
Burnished finish

## Capitelli e coprifili - Doorheads and casings

Le porte Decapata vengono fornite complete di coprifili standard a 45°. Capitelli e coprifili speciali disponibili a richiesta. Vedi anche approfondimento Sezione Capitelli pag. 370.

The Decapata doors are supplied with standard 45° casings. Doorheads and special casings available upon request. See also the detailed section of doorheads and casings at page 370.

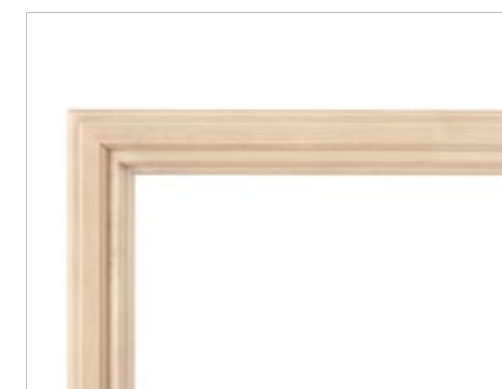

cm 6,4  
Coprifili standard  
Standard casings



Capitello Lineare con coprifili standard  
Flat doorhead with standard casings



Capitello Lineare con rosette con coprifili standard  
Flat doorhead with turned blocks and standard casings



Capitello Centinato con coprifili standard  
Bowed doorhead with standard casings



Capitello a Timpano con coprifili standard  
Gable doorhead with standard casings



cm 11,5  
Capitello Quadrato con coprifili mod. Bastoncino rigato  
Square doorhead with casings mod. Striped strip



cm 11,5  
Capitello Timpano interrotto - coprifili mod. Mensola liscia  
Broken gable doorhead with casings mod. Smooth corbel



cm 11,5  
Capitello Timpano con coprifili mod. Mensola rigata  
Gable doorhead with casings mod. Striped corbel



cm 11,5  
Capitello Lineare con coprifili mod. Bastoncino rigato  
Flat doorhead with casings mod. Striped strip





# Impero

L'esaltazione massima dello stile classico dove le porte s'impreziosiscono di colonne e capitelli per adattarsi ad ambienti ricercati e sontuosi.

The utmost elevation of a classical style where doors are enriched by columns and doorheads to embellish refined and luxurious surroundings.





IMPERO



# IMPERO

L'esaltazione massima di uno stile classico, la bellezza morbida delle linee, la pulizia formale portata allo Zenit. Porte che impreziosiscono ambienti ricercati, la sontuosità di un pezzo unico dove il piacere del dettaglio esplode negli elementi decorativi disponibili in finitura oro o nella medesima tonalità della porta. Le colonne e il capitello esaltano ulteriormente l'importanza di una Collezione sublime.

The utmost elevation of a classical style, the soft beauty of lines, formal neatness at its zenith. Doors that embellish refined surroundings, a luxurious unique piece able to bring out values and centring on itself all the perspective lines around it. The delight of a detail bursts out in the decorative elements: finishes in gold, or the same as the door with columns and doorheads that further highlight the importance of a sublime Collection.

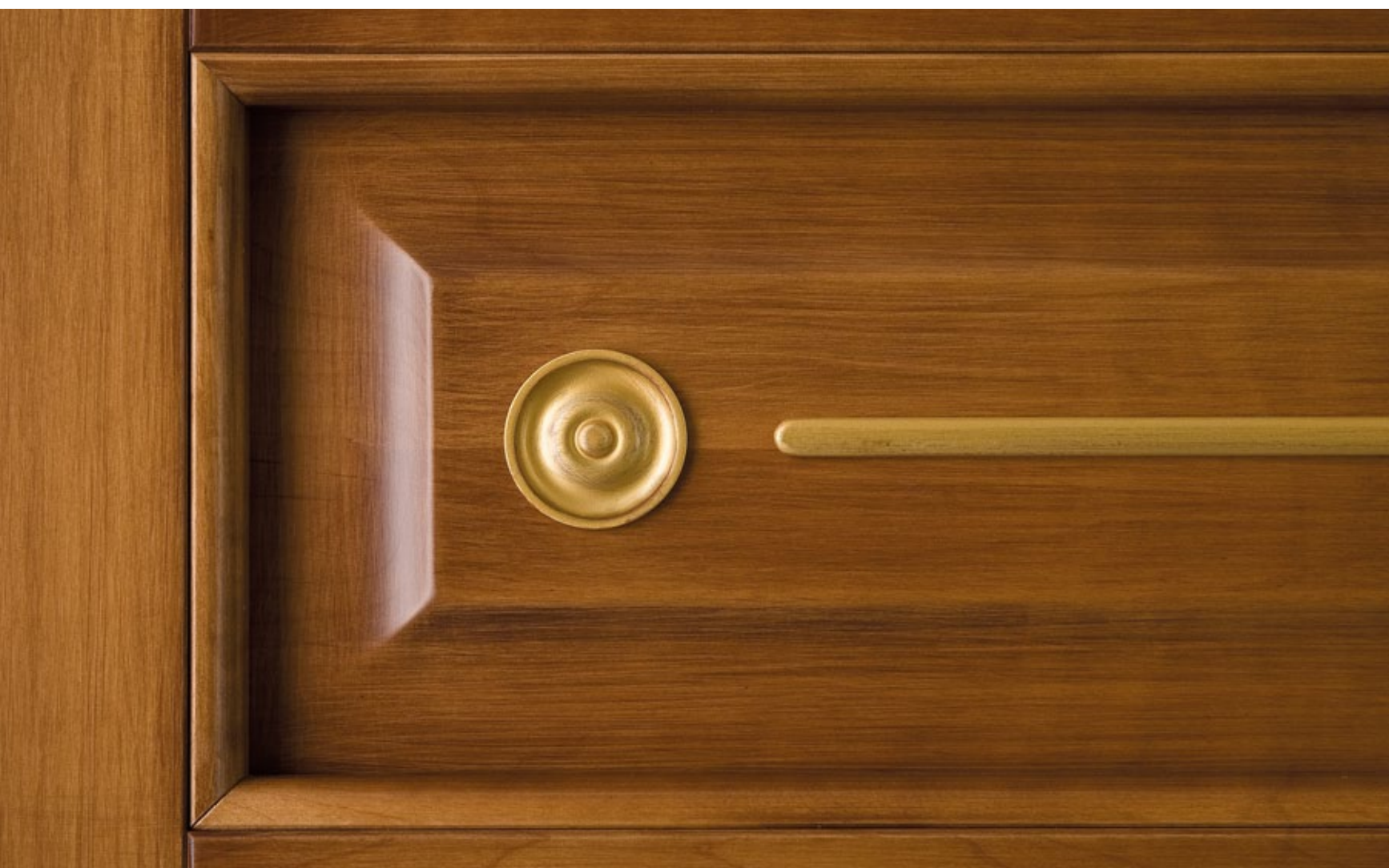

cod. Q-30 Alder anticato noce  
chiaro/particolari oro - Portale  
con capitello lineare/particolari  
oro.

code Q-30 Alder stained antique  
light walnut/gold details  
"Portale" with flat doorhead/gold  
details.

legnoform

# IMPERO





cod. Q-14 Alder anticato noce  
chiaro/particolari anticati  
Portale con capitello a timpano  
particolari anticati.

code Q-14 Alder stained antique  
light walnut/antique details  
"Portale" with gable doorhead  
antique details.



cod. Q-15 Alder anticato noce  
chiaro/particolari oro, cristalli  
satinati bianchi, bisello lucido  
Portale con capitello lineare  
particolari anticati.

code Q-15 Alder stained antique  
light walnut/gold details, white  
satin glass clear bevelled  
"Portale" with flat doorhead  
antique details.





cod. Q-32 Alder anticato noce scuro/particolari anticati  
Portale con capitello timpano interrotto/particolari oro.

code Q-32 Alder stained antique dark walnut/antique details  
"Portale" with broken gable doorhead/gold details.

legnoform

IMPERO





cod. Q-32 Alder anticato noce scuro/particolari oro – Portale con capitello lineare/particolari anticati.

code Q-32 Alder stained antique dark walnut/gold details  
"Portale" with flat doorhead antique details.



cod. Q-13 Alder anticato noce scuro/particolari oro, cristallo doppio legato ottone - Portale con capitello lineare/particolari anticati.

code Q-13 Alder stained antique dark walnut/gold details, double brass beading glass - "Portale" with flat doorhead/antique details.





cod. Q-14 Alder finitura Veneziana/particolari oro - Portale con capitello centinato/particolari oro.  
code Q-14 Alder Veneziana finish/gold details - "Portale" with bowed doorhead/gold details.

Le colonne e il capitello - caratteristiche dell'antica arte greca, dei suoi meravigliosi templi - esaltano ulteriormente l'importanza di una Collezione sublime.

Columns and doorhead - distinctive features of ancient Greek art in its splendid temples - highlight further the importance of a sublime Collection.



# IMPERO





cod. Q-11 Alder finitura  
Veneziana/particolari veneziana  
Portale con capitello centinato  
particolari veneziana.

code Q-11 Alder Veneziana finish  
Venetian details - "Portale" with  
bowed doorhead/Venetian details.



cod. Q-30 Alder finitura  
Veneziana/particolari oro  
Portale con capitello timpano  
interrotto/particolari oro.

code Q-30 Alder Veneziana finish  
gold details - "Portale" with broken  
gable doorhead/gold details.





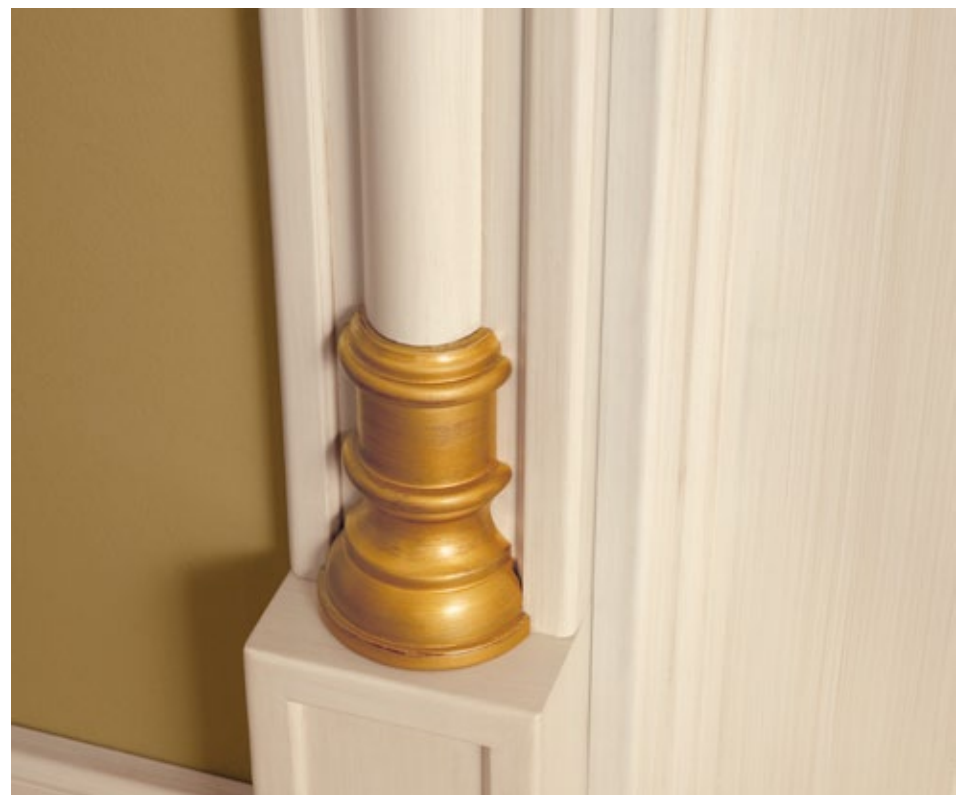

cod. Q-13 Alder finitura Veneziana/particolari oro,  
porta doppio battente con cristalli doppio legato ottone  
Portale con capitello lineare/particolari oro.

code Q-13 Alder Veneziana finish/gold details,  
double-leaf door with double brass beading glass  
"Portale" with flat doorhead/gold details.







# LE SOLUZIONI THE SOLUTIONS

Immagina la porta dei tuoi desideri. Immaginala in casa tua, in un ambiente dove vivere una quotidianità piacevole, appagante, di stile. E immaginala esattamente come vuoi, perché qualunque sia la sua forma, possiamo realizzarla. Grazie alla maestria artigiana Legnoform, sono disponibili soluzioni speciali che consentono di realizzare ogni tua esigenza, con interventi unici realmente a misura di desiderio. Il tuo.

Imagine the door of your wish. Imagine it in your own home, a surrounding in which you can live a gratifying, pleasant and stylish everyday life. And imagine it exactly as you wish and with whatever shape, we can produce it. Legnoform's masterful craftsmanship will allow you to have special solutions uniquely tailored to a wish - your very own.

Alcuni esempi di soluzioni speciali - Some examples of special solutions

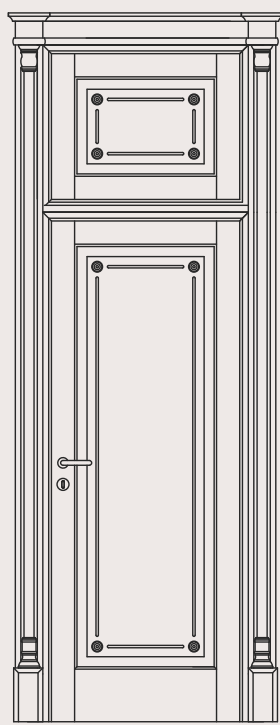

Sopraluce con battente  
Transom with doorleaf

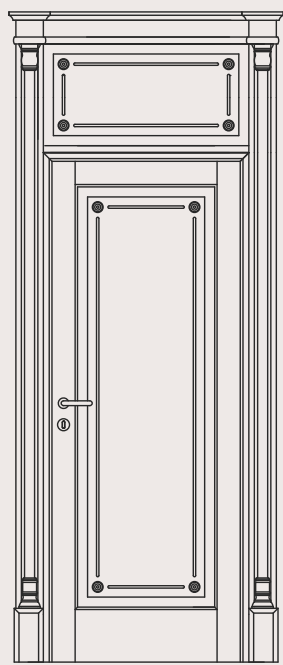

Chiambrana  
"Chiambrana"

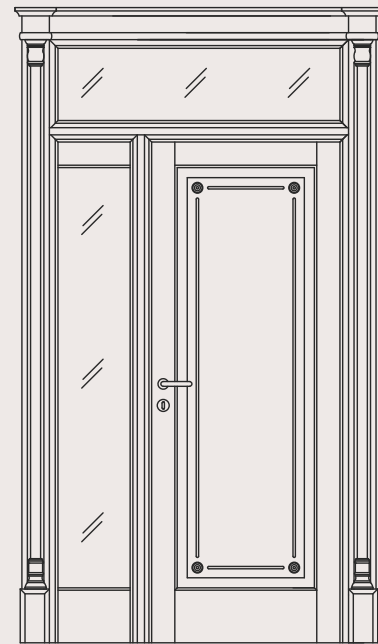

Fianco-luce e sopraluce  
Sidelight with transom window

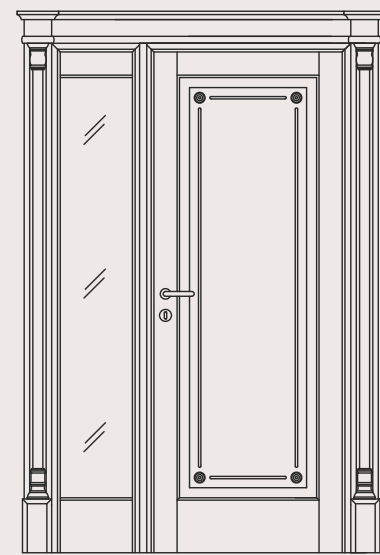

Fianco-luce  
Sidelight





# IMPERO

Porte in legno massello di Nocino Americano - Alder con elementi decorativi inseriti ad incasso nel pannello, disponibili nella finitura porta o nella finitura simil-oro. Portale Impero fornito sul lato principale della porta con particolari torniti disponibili nella finitura porta o finitura simil-oro. Lato secondario della porta fornito completo di coprifili lisci.

Solid wood Alder doors with decorative elements embedded in the panel, available in the same finish as the door or in synthetic gold finish. "Portale" Impero delivered on the main side of the door with column's turned details available in the same finish as the door or in synthetic gold finish. On the inner side of the door, smooth casings.

## I Modelli - The Models

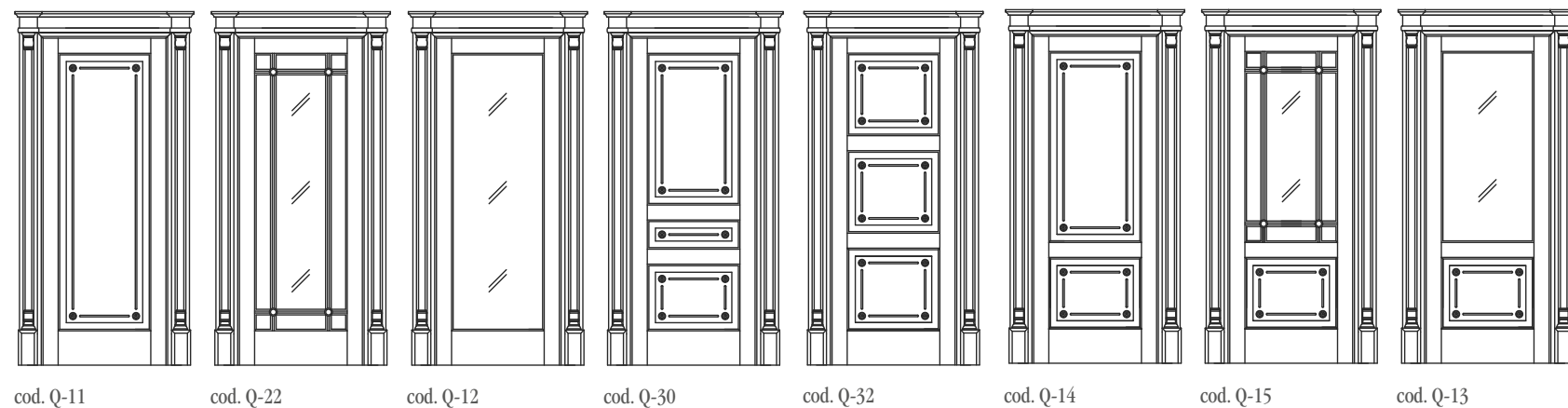

cod. Q-11    cod. Q-22    cod. Q-12    cod. Q-30    cod. Q-32    cod. Q-14    cod. Q-15    cod. Q-13

## Le Finiture Legno - The Wood Finishes



Alder anticato noce chiaro  
Alder stained antique light walnut



Alder anticato noce scuro  
Alder stained antique dark walnut



Alder finitura Veneziana  
Alder Veneziana finish

## I Cristalli - The Glass

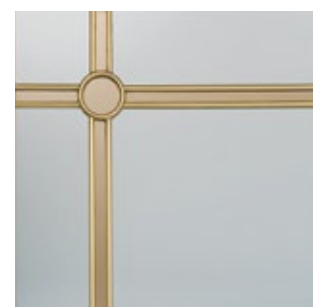

Doppio legato ottone Impero satinato bianco/bronzo  
Impero double brass beading satin white/bronze



Inciso disegno Impero satinato bianco  
Bevel detail Impero white satin

## Le Cerniere - The Hinges

Cerniera in Stile, a pomella, in ottone o in ferro  
Old fashioned pintel hinge in brass or in iron



Finitura ottone satinato  
Mat brass finish



Finitura brunita  
Burnished finish

## Il Portale - The "Portale"

Le porte Impero vengono fornite complete di Portale Impero sul lato principale della porta. Costituito da: capitello Lineare Impero, coprifili Impero (L. cm 11,5) con colonne, elementi torniti e basamento. I particolari torniti sono disponibili nella finitura-porta o in finitura simil-oro. Sul lato secondario della porta coprifili lisci. Altri capitelli Impero disponibili su richiesta.

The Impero doors are supplied with "Portale Impero" on the main side of the door. This is made up with a Flat Impero doorhead, Impero casings (11,5 cm wide) with column, turned details and basement. The turned details are available in the same finish as the door or in synthetic gold finish. On the inner side of the door smooth casings. Other Impero doorheads available upon request.

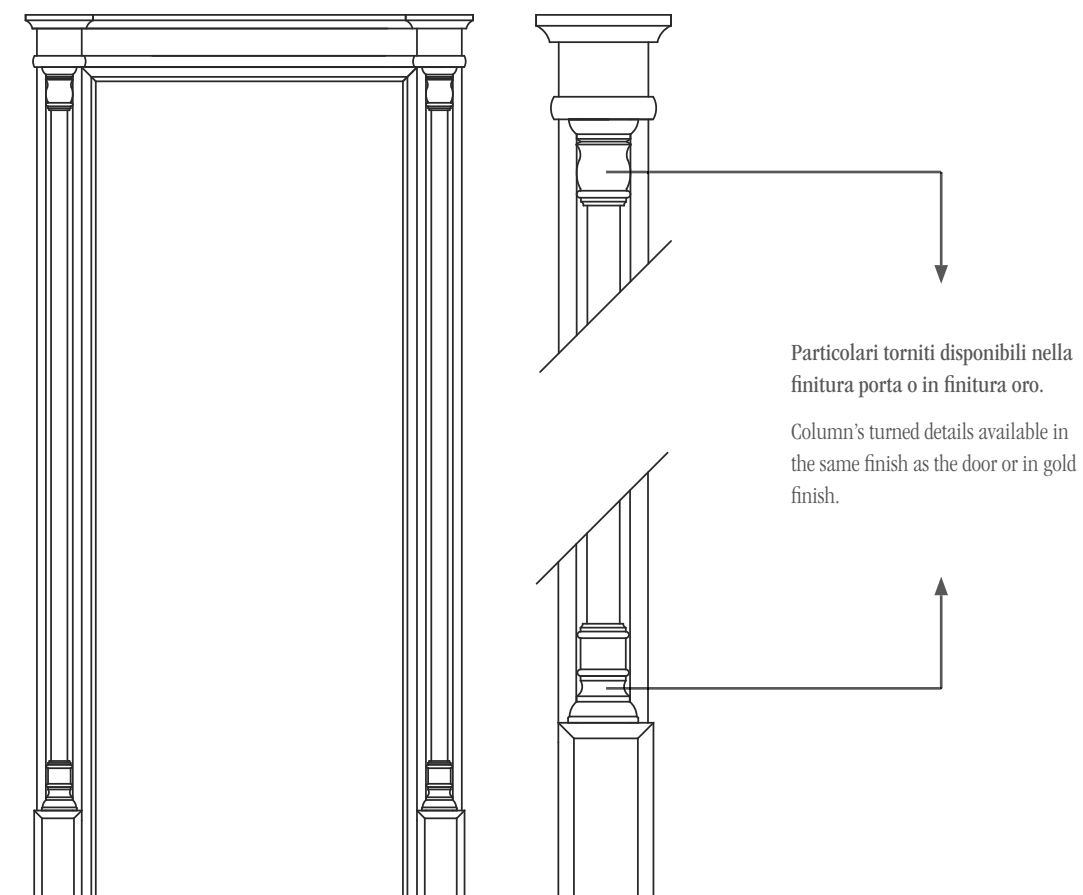

Particolari torniti disponibili nella finitura porta o in finitura oro.

Column's turned details available in the same finish as the door or in gold finish.

## Capitelli Impero - Impero doorheads

Altri capitelli Impero disponibili su richiesta. Other Impero doorheads available upon request.

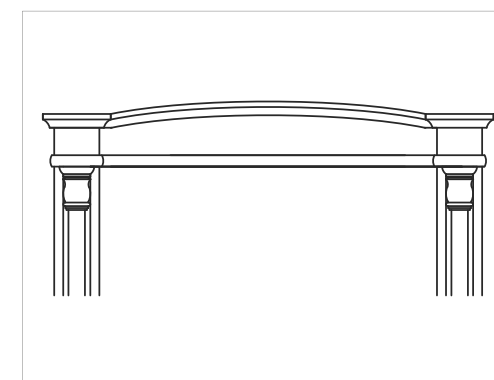

Capitello Centinato  
Bowed doorhead

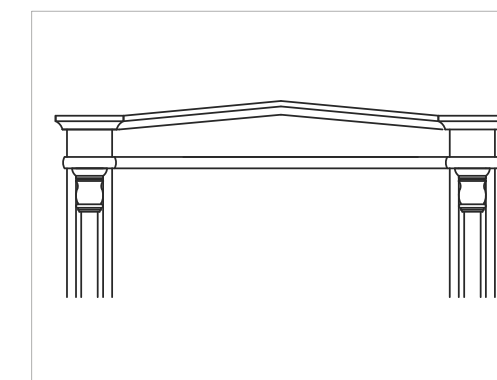

Capitello Timpano  
Gable doorhead

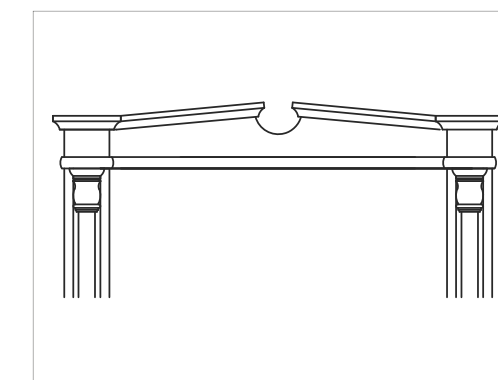

Capitello Timpano interrotto  
Broken Gable doorhead





# LIBERTY

## LIBERTY

Una collezione di porte che vive e si snoda intorno a linee morbide e tondeggianti, dalle forme inconfondibili e dall'eleganza formale assoluta.

A range of interior doors which lives and weaves around in soft and rounded lines, unusual designs of utmost formal elegance.





LIBERTY



# LIBERTY

Una corrente artistica che affonda le sue radici nell'ispirazione naturale, dalle sue forme, seme creativo che genera linee dinamiche, ondulate, armonie tondeggianti.

Nasce da questo percorso la Collezione Liberty, nel solco di una corrente culturale che ha segnato il diciannovesimo secolo e generato forme inconfondibili, di eleganza formale assoluta.

The Liberty collection embodies in the door a style that embellished the nineteenth century and became a milestone in modern art.

A range of interior doors in solid wood Alder which lives and weaves around in soft and rounded lines.

Unusual designs in perfect tune with the artistic style from which they take their name.



cod. C-50 Alder anticato noce chiaro.

code C-50 Alder stained antique light walnut.

# LIBERTY

legnoform





cod. C-31 Alder anticato noce chiaro, porta doppio battente con cristalli satinati e decoro nastri (Tipo B).

code C-31 Alder stained antique light walnut, double-leaf door, glass satin and with Ribbons motifs (Type B).



cod. C-30 Alder anticato noce chiaro - cristallo satinato.

code C-30 Alder stained antique light walnut - satin glass.





cod. C-10 Alder anticato noce scuro  
cristallo inciso.

code C-10 Alder stained antique dark walnut  
glass with etched decor.



cod. C-11 Alder anticato noce scuro  
cristalli satinati ed inciso (Tipo A).

code C-11 Alder stained antique dark walnut  
glass satin and with etched decor (Type A).





cod. C-50 Alder anticato  
noce chiaro.

code C-50 Alder stained  
antique light walnut.

cod. C-51 Alder anticato noce chiaro  
cristallo decoro nastri.

code C-51 Alder stained antique light walnut  
glass with Ribbons motifs.



cod. C-31 Alder anticato noce  
scuro - cristalli satinati e con  
decoro nastri (Tipo A).

code C-31 Alder stained antique  
dark walnut - glass satin and  
with Ribbons motifs (Type A).





cod. C-21 Alder anticato mogano  
cristalli incisi.

code C-21 Alder stained antique mahogany  
glass with etched decor.

cod. C-21 Alder anticato mogano  
cristalli decoro nastri.

code C-21 Alder stained antique mahogany  
glass with Ribbons motifs.



cod. C-20 Alder anticato  
mogano.

code C-20 Alder stained antique  
mahogany.





LIBERTY



La collezione Liberty si impreziosisce con l'utilizzo della radica, legno dall'eccezionale pregio che coinvolge i sensi, con il suo calore. Disponibile su tutti i modelli in tre colori anticati.

The Liberty collection is enriched through the use of briar walnut, a highly prized wood that captivates the senses through its warmth. Available on all the models in three wood finishes.



cod. C-10 Alder/Radica  
anticato noce chiaro  
cristallo satinato.

code C-10 Alder/Briar wood  
stained antique light walnut  
satin glass.

# LIBERTY

**legnoform**



cod. C-20 Alder/Radica anticato  
mogano.  
code C-20 Alder/Briar wood stained  
antique mahogany.



cod. C-30 Alder/Radica anticato  
mogano - cristallo decoro nastri.  
code C-30 Alder/Briar wood stained  
antique mahogany - glass with  
Ribbons motifs.





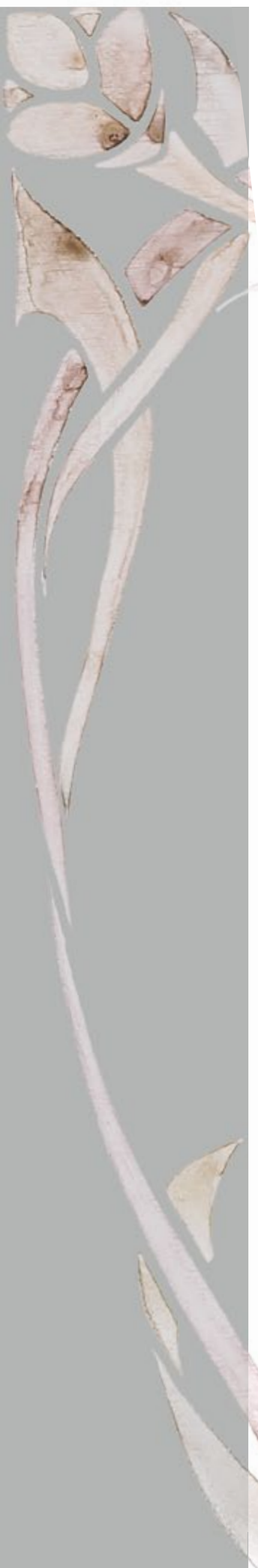

LIBERTY

Le Veneziane - The Veneziana doors





cod. C-51 Alder finitura Veneziana, porta doppio battente - cristalli decoro nastri.

code C-51 Alder Veneziana finish, double-leaf door, glass with Ribbons motifs.



cod. C-50 Alder finitura Veneziana.

code C-50 Alder Veneziana finish.



Lo stile Liberty affonda le proprie radici nella creazione libera come alternativa a quella in serie. Allo stesso modo, la collezione Liberty di Legnoform consegna la cura dei particolari alla maestria artigiana di autentici artisti.

The Liberty style takes its roots in free creation as opposed to standard production. In the same way, the Liberty collection from Legnoform entrusts its attention to detail to the master craftsmanship of true artists.



cod. C-10 Alder finitura  
Veneziana - cristallo inciso.

code C-10 Alder Venezia  
finish glass with etched decor.

**legnoform**

LIBERTY





cod. C-11 Alder finitura  
Veneziana - cristalli satinati.

code C-11 Alder Veneziana finish  
satin glass.

cod. C-11 Alder finitura Veneziana  
cristalli decoro nastri (Tipo C).

code C-11 Alder Veneziana finish  
glass with Ribbons motifs (Type C).



cod. C-21 Alder finitura  
Veneziana - cristalli incisi.

code C-21 Alder Veneziana finish  
glass with etched decor.

cod. C-21 Alder finitura Veneziana  
cristalli decoro nastri.

code C-21 Alder Veneziana finish  
glass with Ribbons motifs.





LIBERTY

I Laccati - The lacquered doors





cod. C-30 Alder finitura laccato bianco - cristallo satinato.

code C-30 Alder white lacquered finish - satin glass.

cod. C-31 Alder finitura laccato bianco cristalli satinati e decoro nastri (Tipo B).

code C-31 Alder white lacquered finish - glass satin and with Ribbons motifs (Type B).



cod. C-41 Alder finitura laccato bianco - cristalli incisi.

code C-41 Alder white lacquered finish - glass with etched decor.



# LE SOLUZIONI

THE SOLUTIONS

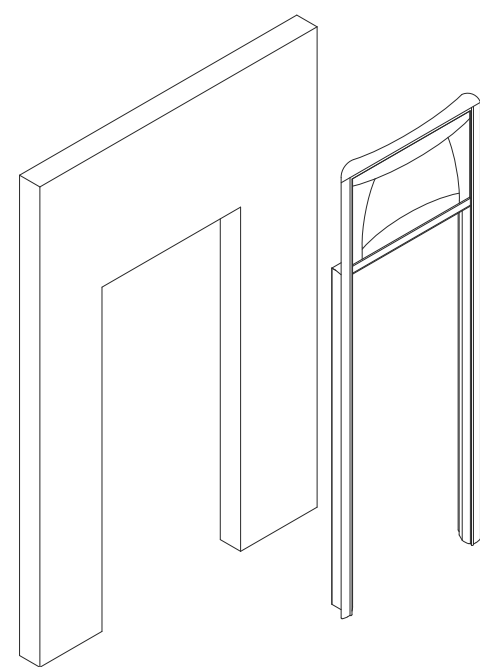

## LE CHIAMBRANE

Le Chiambrane Legnoform, soluzioni dal grande impatto visivo che permettono di essere installate senza apporre alcuna modifica muraria. Disponibili su tutti i modelli della collezione.

Le Chiambrane Legnoform, exceptionally eye-catching solutions that can be installed without changing the wall openings on all the models of the collection.



# LIBERTY



# LE SOLUZIONI

## THE SOLUTIONS

Immagina la porta dei tuoi desideri. E immaginala esattamente come vuoi, perché qualunque sia la sua forma, possiamo realizzarla. Grazie alla maestria artigiana Legnoform, sono disponibili soluzioni speciali che consentono di realizzare ogni tua esigenza, con interventi unici.

Imagine the door of your wish. And imagine it exactly as you wish and with whatever shape, we can produce it. Legnoform's masterful craftsmanship will allow you to have special solutions uniquely tailored to your wish.



Porte a doppio battente con sopraluce e doppio fianco-luce.

Double-leaf doors with transom window and side-lights.

legnoform

# LIBERTY



# I CRISTALLI

## THE CRYSTAL GLASS

### INCISI

Cristalli che vengono impreziositi da incisioni di raffinata eleganza. Figure semplici che si evolvono e prendono vita sinuosa, astratta, qui proposte su porte in finitura legno.

### ETCHED DECOR

Crystal glass enriched through stylishly elegant etching. Basic patterns evolve to slender abstract life, here shown on doors in wood finish.



cod. C-21



cod. C-11 Tipo A - Type A



cod. C-11 Tipo C - Type C



cod. C-51



cod. C-41



cod. C-31 Tipo A - Type A



cod. C-31 Tipo B - Type B



cod. C-31 Tipo C - Type C

Cristalli di sicurezza, temprati, satinati bianchi con incisione lucida.  
Tempered safety crystal glass, white satin with shiny etching.

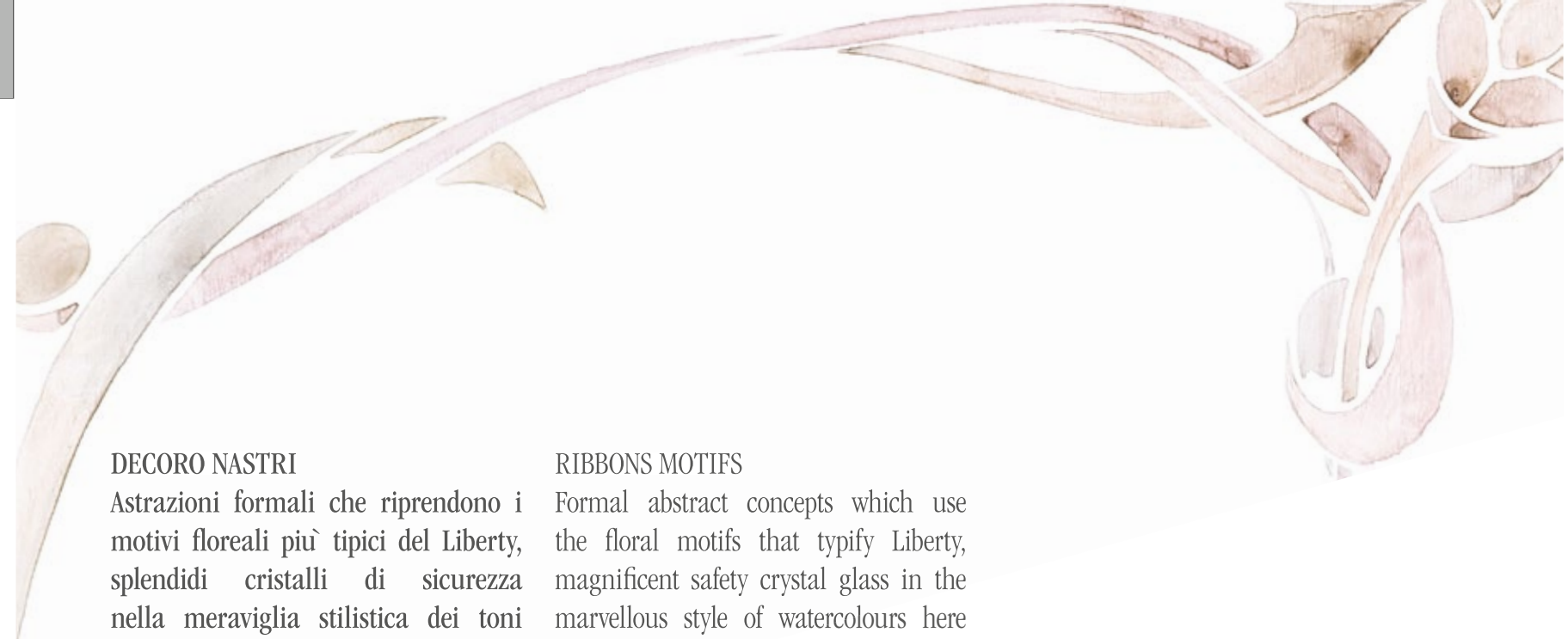

### DECORO NASTRI

Astrazioni formali che riprendono i motivi floreali più tipici del Liberty, splendidi cristalli di sicurezza nella meraviglia stilistica dei toni acquerello, qui proposti su porte in finitura legno.

### RIBBONS MOTIFS

Formal abstract concepts which use the floral motifs that typify Liberty, magnificent safety crystal glass in the marvellous style of watercolours here shown on doors in wood finish.



cod. C-21



cod. C-11 Tipo A - Type A



cod. C-11 Tipo C - Type C



cod. C-51



cod. C-41



cod. C-31 Tipo A - Type A



cod. C-31 Tipo B - Type B



cod. C-31 Tipo C - Type C

Cristalli di sicurezza, accoppiati, satinati bianchi con decori nei toni acquerello.  
Dual safety crystal glass, white satin with watercolour motifs.

legnoform



# I CRISTALLI

## THE CRYSTAL GLASS

### INCISI

Cristalli che vengono impreziositi da incisioni di raffinata eleganza. Figure semplici che si evolvono e prendono vita sinuosa, astratta, qui proposte su porte laccate bianche.

### ETCHED DECOR

Crystal glass enriched through stylishly elegant etching. Basic patterns evolve to slender abstract life, here shown on white lacquered doors.



cod. C-21



cod. C-11 Tipo A - Type A



cod. C-11 Tipo C - Type C



cod. C-51



cod. C-41



cod. C-31 Tipo A - Type A



cod. C-31 Tipo B - Type B



cod. C-31 Tipo C - Type C

Cristalli di sicurezza, temprati, satinati bianchi con incisione lucida.  
Tempered safety crystal glass, white satin with shiny etching.

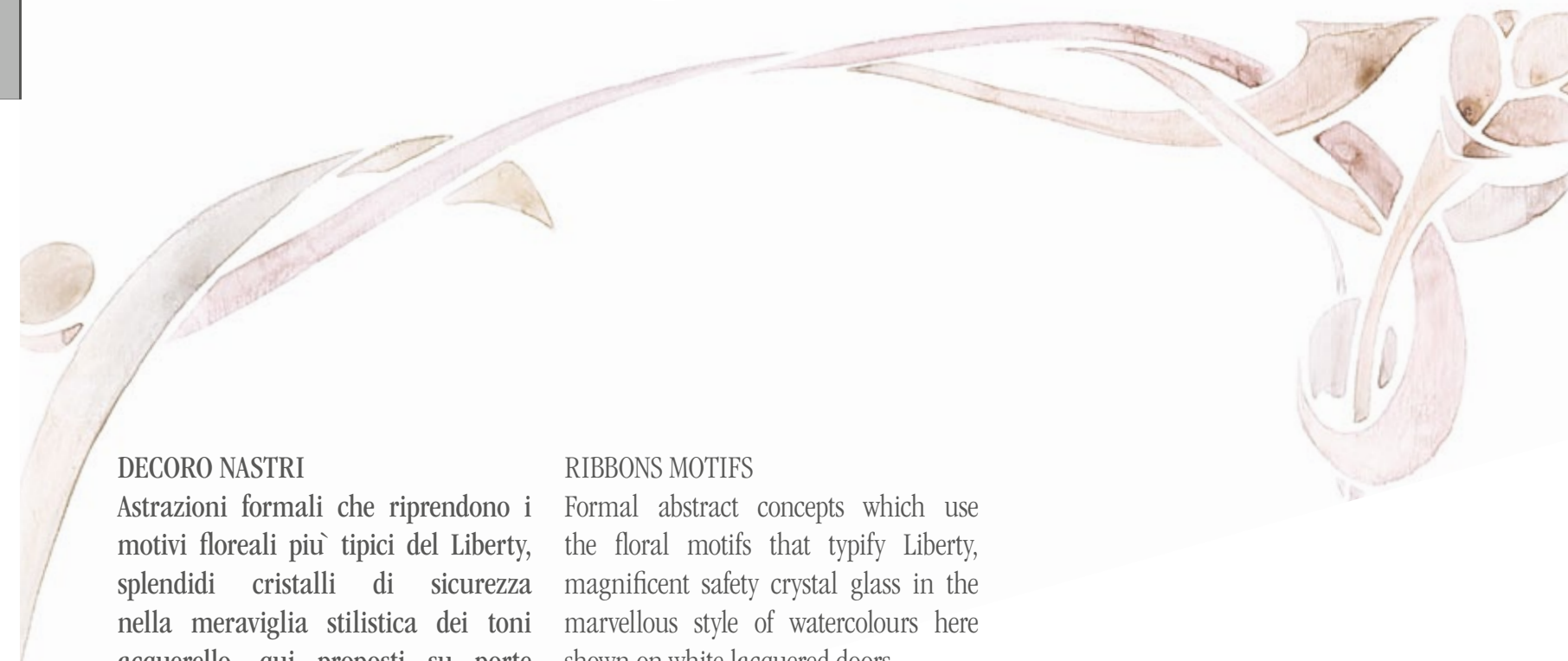

### DECORO NASTRI

Astrazioni formali che riprendono i motivi floreali più tipici del Liberty, splendidi cristalli di sicurezza nella meraviglia stilistica dei toni acquerello, qui proposti su porte laccate bianche.

### RIBBONS MOTIFS

Formal abstract concepts which use the floral motifs that typify Liberty, magnificent safety crystal glass in the marvellous style of watercolours here shown on white lacquered doors.



cod. C-21



cod. C-11 Tipo A - Type A



cod. C-11 Tipo C - Type C



cod. C-51



cod. C-41



cod. C-31 Tipo A - Type A



cod. C-31 Tipo B - Type B



cod. C-31 Tipo C - Type C

Cristalli di sicurezza, accoppiati, satinati bianchi con decori nei toni acquerello.  
Dual safety crystal glass, white satin with watercolour motifs.

legnoform





# LIBERTY

Porte in legno massello di Nocino Americano-Alder con telaio stonato, traversa coprifilo sagomata ed angoli arrotondati.

Solid wood Alder doors with rounded frame and bowed casing's crosspiece with rounded corners.

## I Modelli - The Models

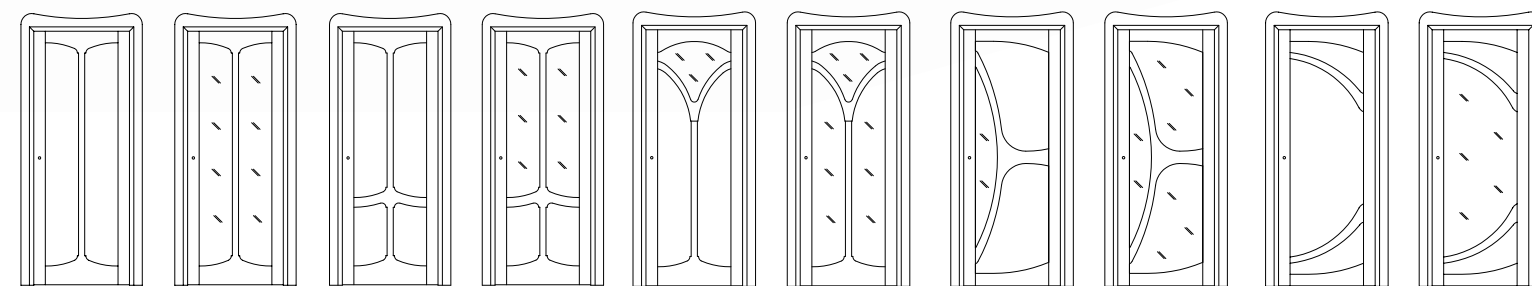

cod. C-20    cod. C-21    cod. C-40    cod. C-41    cod. C-10    cod. C-11    cod. C-30    cod. C-31    cod. C-50    cod. C-51

## Le Finiture - The Finishes



Alder anticato noce chiaro  
Alder stained antique light walnut



Alder anticato noce scuro  
Alder stained antique dark walnut



Alder anticato mogano  
Alder stained antique mahogany



Alder finitura Veneziana  
Alder Veneziana finish



Alder finitura laccato bianco  
Alder white lacquered finish

## Le Cerniere - The Hinges

Cerniera a pomella, in ottone, disponibile in 4 finiture

Pintel hinge in brass, available in 4 finishes



Finitura ottone lucido  
Polished brass finish



Finitura ottone satinato  
Mat brass finish



Finitura cromato lucido  
Polished chrome finish



Finitura cromato satinato  
Mat chrome finish

# LIBERTY





*Country* pag. 250

*Consumata* pag. 268

*Arte Povera* pag. 282

*Roviniò* pag. 298

Lavorazioni che sanno di antico, di caldo, che coinvolgono i sensi, che regalano un effetto che va oltre il bello ottenuto grazie alla straordinaria manualità di esperti artigiani.

Sensations of antiquity, warmth that conjure up all senses, offering an effect that goes beyond beauty alone achieved through the skilled handwork of expert craftsmen.





*Country*



# Country

La grande difficoltà di plasmare un capolavoro, trasformandolo in un perfetto esempio di artigianato povero, l'umiltà di dare splendore senza l'eccesso.

Il legno massello viene lavorato attraverso procedimenti complessi per ricreare l'effetto di una porta usurata dal tempo. L'assemblaggio a coda di rondine e spine di legno e la traversa del coprifilo che ricorda un'architrave conferiscono sapori antichi, preziosi, stili di memorabile stile.

The great effort in shaping a masterpiece, converting it into a perfect example of humble splendour avoiding overindulgence.

The solid wood is crafted through complex procedures to create the unique effect of a door that seems aged. The aged effect is completed by dovetailing and doweling whilst the crosspiece of the casing conjures up an architrave with the precious flavour of yesteryear with touches of memorable style.



cod. T-25 Larice finitura naturale - cristallo stirato bianco.

code T-25 Larchwood natural finish - "stirato" white glass.

# Country

legnoform





cod. T-21 Larice finitura naturale.  
code T-21 Larchwood natural finish.

L'assemblaggio a coda di rondine con spine di legno e la traversa del coprifilo che ricorda un'architrave conferiscono sapori antichi, preziosi, stile di memorabile stile.

The aged effect is completed by dovetailing and doweling whilst the crosspiece of the casing conjures up an architrave with the precious flavour of yesteryear with touches of memorable style.

*Country*







cod. T-23 Larice finitura naturale - cristallo stirato bianco.

code T-23 Larchwood natural finish - "stirato" white glass.



cod. T-14 Larice finitura naturale.

code T-14 Larchwood natural finish.

*Country*

**legnoform**



cod. T-15 Rovere finitura fondo  
chiaro - cristallo stirato bianco.

code T-15 Oak light base finish  
"stirato" white glass.



cod. T-24 Rovere finitura fondo chiaro.  
code T-24 Oak light base finish.

Country





cod. T-21 Rovere finitura fondo scuro.  
code T-21 Oak dark base finish.



cod. T-24 Rovere finitura fondo scuro.  
code T-24 Oak dark base finish.

*Country*

**legnoform**





cod. T-15 Rovere finitura decapato bianco - cristallo stirato bianco.  
code T-15 Oak "decapato" white finish - "stirato" white glass.

*Country*





cod. T-14 Rovere finitura  
decapato bianco.

code T-14 Oak "decapato" white  
finish.

*Country*

**legnoform**



# Country

Porte in legno massello di Larice o Rovere con effetto usurato dal tempo. Coprifili con architrave aggettante.

Solid wood doors in Larchwood or Oak with aged effect. Casings supplied with overhanging architrave.

## I Modelli - The Models

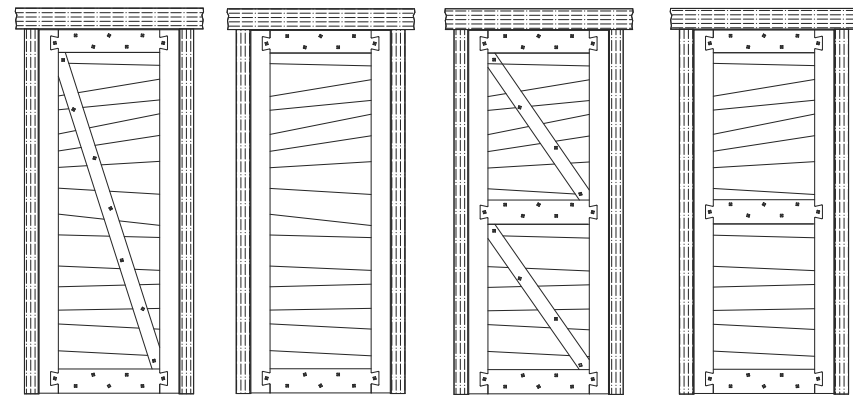

cod. T-21      cod. T-11      cod. T-24      cod. T-14

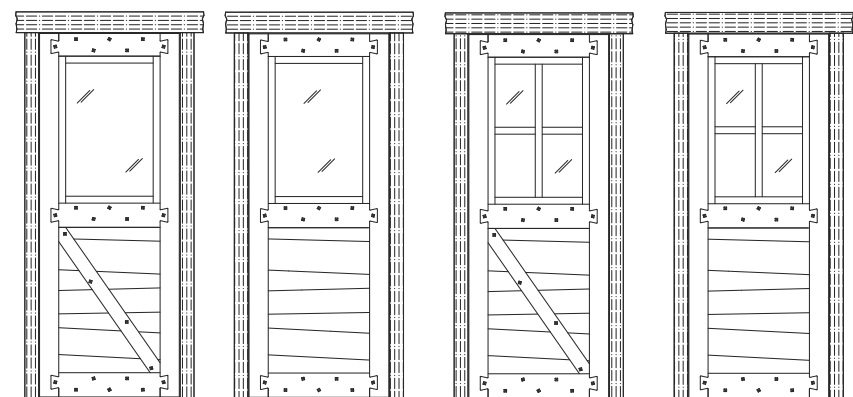

cod. T-23      cod. T-13      cod. T-25      cod. T-15

## Le Finiture Legno - The Wood Finishes

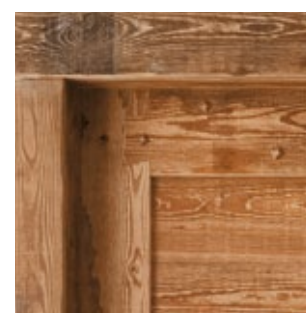

Larice naturale  
Larchwood natural

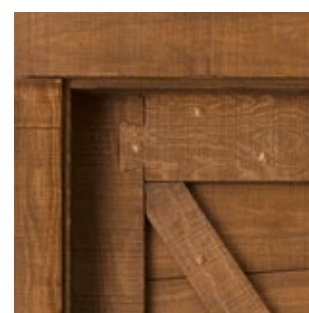

Rovere fondo chiaro  
Oak light base

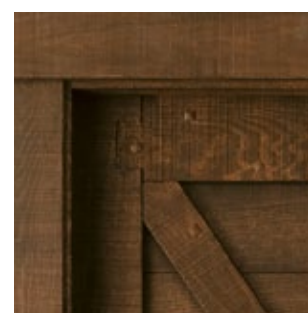

Rovere fondo scuro  
Oak dark base

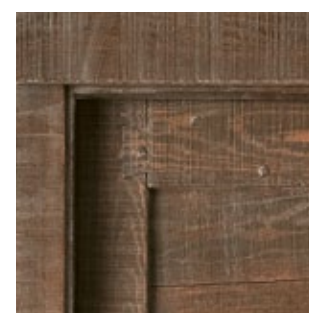

Rovere decapato bianco  
Oak "decapato" white

## I Cristalli - The Glass



Stirato bianco  
"Stirato" white



Stirato giallo  
"Stirato" yellow

## Le Cerniere - The Hinges

Cerniera a pomella,  
in ferro, forgiata  
a farfalla  
Pintel hinge in iron,  
forged mod. butterfly



Finitura brunita  
Burnished finish

Maniglie disponibili a richiesta  
Handles available upon request

Maniglia RB tonda - Handle RB round

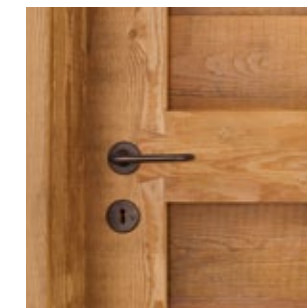

Fronte  
Front

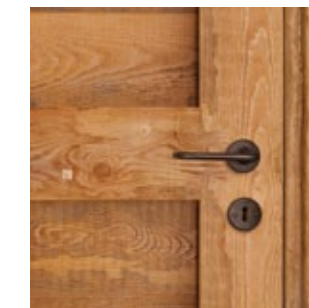

Retro  
Rear

Maniglie RB tonda con Serratura a scatola  
Handle RB round with special lock

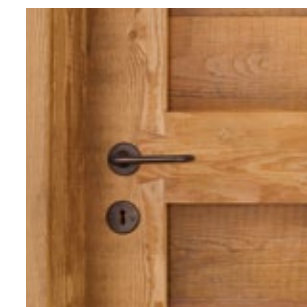

Fronte  
Front

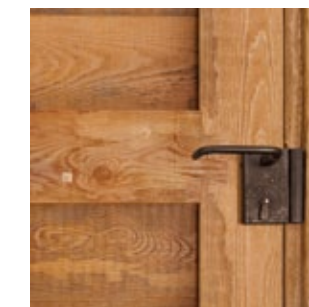

Retro  
Rear

Cricca - "Cricca"

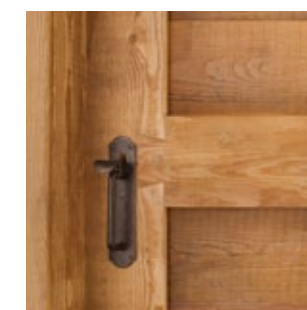

Fronte  
Front

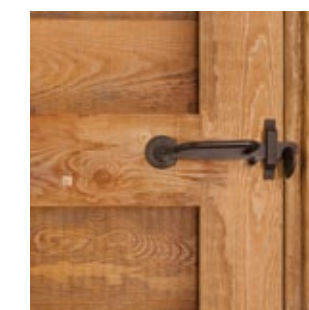

Retro  
Rear

Cricca con serratura - "Cricca" with lock

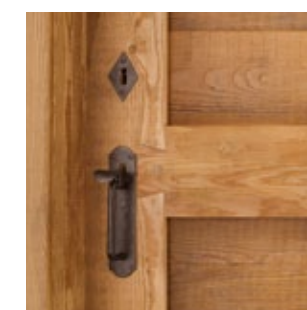

Fronte  
Front

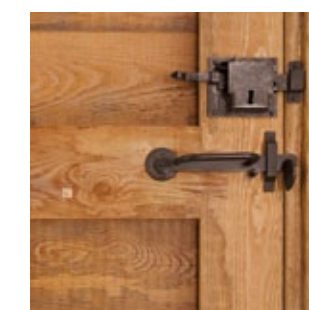

Retro  
Rear



*Consumata*





# Consumata

I segni del tempo. Significano storia, passato che impreziosisce, che segna come una ruga. Una ruga generata dalle emozioni di una vita. L'effetto consumato è ottenuto tramite lavoro di abrasione, che dona alla superficie l'irregolare fascino del vissuto. Conservando tutta la robusta essenza del massello.

Signs of time, indicating history. A past which enriches and which marks like a wrinkle. A wrinkle born of the emotions of a lifetime. This aged effect is achieved through abrasion, which gives the door the charm of days gone by, preserving the quintessential sturdiness of solid wood.



cod. 5-30 Rovere finitura fondo chiaro - coprifili standard.

code 5-30 Oak light base finish standard casings.

# Consumata

legnoform





cod. 5-32 Rovere finitura fondo  
chiaro - coprifili standard.

code 5-32 Oak light base finish  
standard casings.



cod. 2-14 Rovere finitura fondo  
chiaro - coprifili standard.

code 2-14 Oak light base finish  
standard casings.

*Consumata*

**legnoform**





Porte in legno massello di Rovere dalla superficie irregolare e non uniforme; disponibili in tre finiture: fondo chiaro, fondo scuro e grigio.

Solid wood Oak doors with uneven and irregular surfaces. Three finishes available: light base, dark base and grey.



cod. 5-31 Rovere finitura grigio  
coprifili standard.

code 5-31 Oak grey finish  
standard casings.



cod. 1-15 Rovere finitura grigio  
coprifili lisci.

code 1-15 Oak grey finish  
smooth casings.

*Consumata*

**legnoform**





cod. 5-30 Rovere finitura fondo scuro - coprifili standard.

code 5-30 Oak dark base finish standard casings.



cod. 5-40 Rovere finitura fondo scuro - coprifili standard.

code 5-40 Oak dark base finish standard casings.

*Consummata*

**legnoform**



# Le Soluzioni The Solutions

Immagina la porta dei tuoi desideri. Immaginala in casa tua, in un ambiente dove vivere una quotidianità piacevole, appagante, di stile. E immaginala esattamente come vuoi, perché qualunque sia la sua forma, possiamo realizzarla. Grazie alla maestria artigiana Legnoform, sono disponibili soluzioni speciali che consentono di realizzare ogni tua esigenza, con interventi unici realmente a misura di desiderio. Il tuo.

Imagine the door of your wish. Imagine it in your own home, a surrounding in which you can live a gratifying, pleasant and stylish everyday life. And imagine it exactly as you wish and with whatever shape, we can produce it. Legnoform's masterful craftsmanship will allow you to have special solutions uniquely tailored to a wish – your very own.

Alcuni esempi di soluzioni speciali - Some examples of special solutions

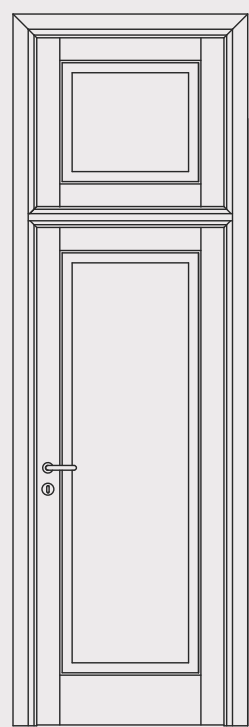

Sopraluce con battente  
Transom with doorleaf

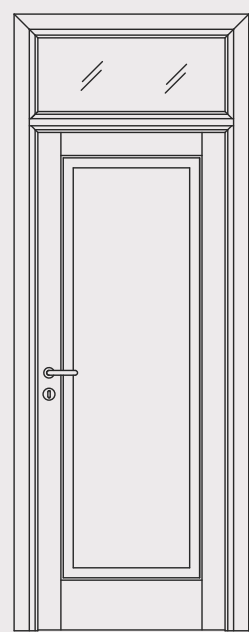

Sopraluce a vetro  
Transom window

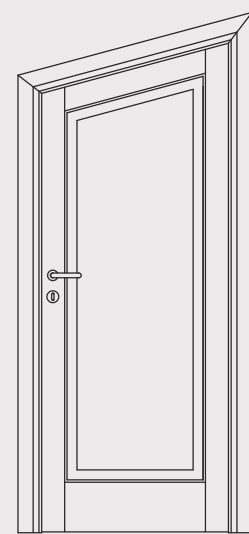

Porta obliqua  
Oblique door

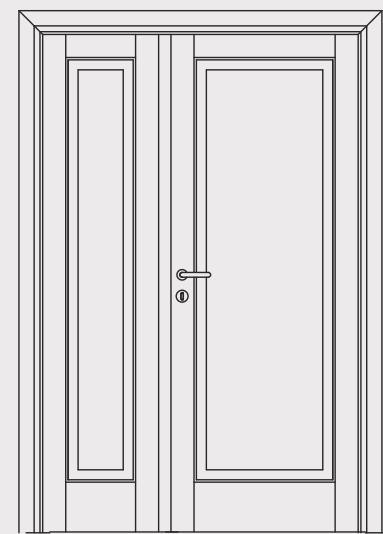

Doppia asimmetrica  
Asymmetrical double door



Consumata



# Consumata

Porte in legno massello di Rovere consumato. Ogni modello è disponibile nella versione a 2 battenti e predisposto per vetro. Coprifili standard a 45°.

Solid wood Oak doors, aged effect. Each model is available in the double-door version and can be fitted with glass. Standard 45° casings.

## I Modelli - The Models

La lavorazione Consumata è realizzabile su tutte le Serie Legnoform ad eccezione della Serie 400 e 700 Rettangolare.

The Consumata finish is available on all Legnoform's Series, with the exception of Serie 400 and Serie 700 Rectangular.

## Le Finiture Legno - The Wood Finishes



Rovere fondo chiaro  
Oak light base



Rovere fondo scuro  
Oak dark base



Rovere grigio  
Oak grey

## I Cristalli - The Glass

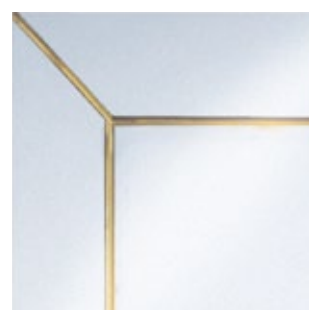

Legato ottone satinato  
bianco - bisello lucido  
White satin - clear bevelled with  
brass beading

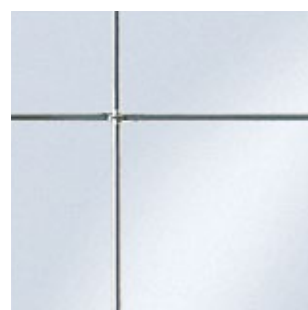

Legato piombo  
Leaded glass

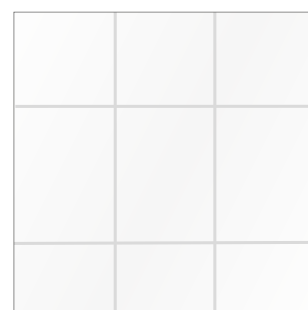

Inciso all'inglese, satinato  
bianco - bisello lucido  
Bevel detail section - white  
satin, clear bevelled

## Le Cerniere - The Hinges

Cerniera in Stile,  
a pomella in ferro  
Old fashioned pintel  
hinge in iron



Finitura brunita  
Burnished finish

## Capitelli e coprifili - Doorheads and casings

Le porte Consumata vengono fornite complete di coprifili standard a 45°. Capitelli e coprifili speciali disponibili a richiesta. Vedi anche approfondimento Sezione Capitelli pag. 370.

The Consumata doors are supplied with standard 45° casings. Doorheads and special casings available upon request. See also the detailed section of doorheads and casings at page 370.



Coprifili standard  
Standard casings



Capitello Lineare con coprifili standard  
Flat doorhead with standard casings



Capitello Centinato con coprifili standard  
Bowed doorhead with standard casings



Capitello Timpano con coprifili standard  
Gable doorhead with standard casings







*Arte Povera*



# Arte Povera

Un trattamento speciale, prezioso come sanno essere preziose le cose artigianali, rese uniche dalla manualità artigianale. Impressioni che sanno di antico, di caldo, che coinvolgono tutti i sensi e riportano a una dimensione intima. La superficie del prezioso massello viene piallata a mano e rifinita con effetto cera. Per un tocco distintivo inimitabile.

A special process, with all the richness of hand made craftsmanship, resulting in something quite unique. Sensations of antiquity and warmth conjuring up all the senses to an intimate dimension. The surface of the solid wood is entirely hand-planed by skilled craftsmen and finished with a "wax effect" to add a distinctive and inimitable touch.



cod. 1-11 Alder fondo noce,  
coprifili a 90°.

code 1-11 Alder walnut base,  
90° casings.

# Arte Povera

legnoform





cod. 3-36 Alder fondo noce, porta doppio battente con cristalli cattedrale - coprifili a 90°.

code 3-36 Alder walnut base, double-leaf door with "cattedrale" glass 90° casings.



cod. 3-14 Alder fondo noce coprifili a 90°.

code 3-14 Alder walnut base 90° casings.



cod. 3-13 Alder fondo noce cristallo legato piombo - coprifili a 90°.

code 3-13 Alder walnut base leaded glass - 90° casings.

Arte Povera

legnoform





*Arte Povera*



cod. 5-40 Alder fondo noce  
coprifili a 90°.

code 5-40 Alder walnut base  
90° casings.



cod. 6-14 Alder fondo noce  
coprifili a 90°.

code 6-14 Alder walnut base  
90° casings.



**legnoform**





cod. 2-15 Alder fondo noce, cristallo stirato bianco/giallo - coprifili 90°.  
code 2-15 Alder walnut base, "stirato" glass white/yellow - 90° casings.

*Arte Povera*



Porte dalla superficie piallata a mano e rifinita con effetto cera per rivivere l'atmosfera speciale delle cose antiche.

Doors with hand-planed surfaces, finished with a wax effect to live the cosy atmosphere of days gone by.





cod. 3-15 Alder fondo ciliegio - cristallo cattedrale  
coprifili a 90°.

code 3-15 Alder cherry base - "cattedrale" glass  
90° casings.



cod. 5-30 Alder fondo ciliegio  
coprifili a 90°.

code 5-30 Alder cherry base  
90° casings.



cod. 5-50 Alder fondo ciliegio, porta doppio battente  
coprifili a 90°.

code 5-50 Alder cherry base, double-leaf door  
90° casings.



*Arte Povera*



# Le Soluzioni The Solutions

Immagina la porta dei tuoi desideri. Immaginala in casa tua, in un ambiente dove vivere una quotidianità piacevole, appagante, di stile. E immaginala esattamente come vuoi, perché qualunque sia la sua forma, possiamo realizzarla. Grazie alla maestria artigiana Legnoform, sono disponibili soluzioni speciali che consentono di realizzare ogni tua esigenza, con interventi unici realmente a misura di desiderio. Il tuo.

Imagine the door of your wish. Imagine it in your own home, a surrounding in which you can live a gratifying, pleasant and stylish everyday life. And imagine it exactly as you wish and with whatever shape, we can produce it. Legnoform's masterful craftsmanship will allow you to have special solutions uniquely tailored to a wish – your very own.

Alcuni esempi di soluzioni speciali - Some examples of special solutions

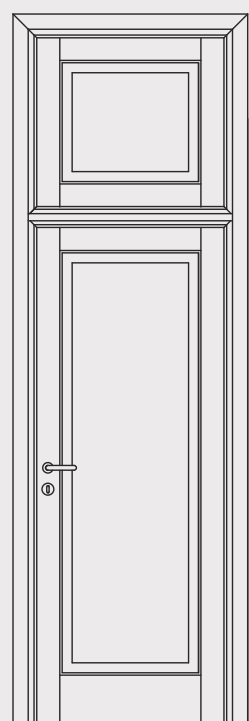

Sopraluce con battente  
Transom with doorleaf

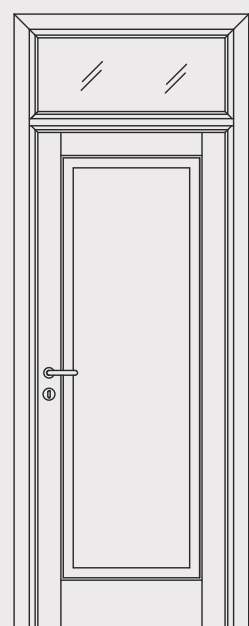

Sopraluce a vetro  
Transom window

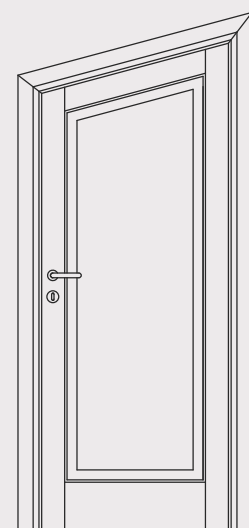

Porta obliqua  
Oblique door

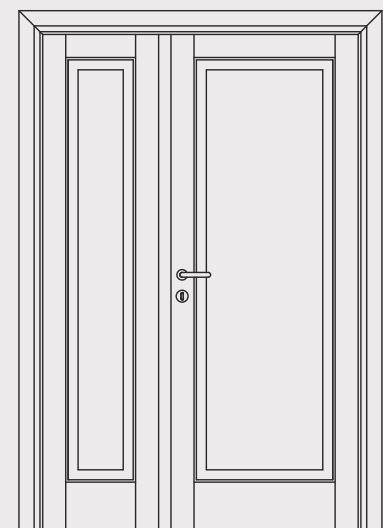

Doppia asimmetrica  
Asymmetrical double door



Arte Povera



# Arte Povera

Porte in legno massello di Nocino Americano Alder piallate a mano. Ogni modello è disponibile nella versione a 2 battenti. Coprifili a 90°.

Solid wood Alder doors hand planed. Each model is available in the double-door version and can be fitted with glass. 90° casings

## I Modelli - The Models

La lavorazione Arte Povera è realizzabile su tutte le Serie Legnoform ad eccezione della Serie 400 e 700 Rettangolare.

The Arte Povera finish is available on all Legnoform's Series with the exception of Serie 400 and Serie 700 Rectangular.

## Le Finiture Legno - The Wood Finishes



Alder fondo noce  
Alder walnut base



Alder fondo ciliegio  
Alder cherry base

## I Cristalli - The Glass

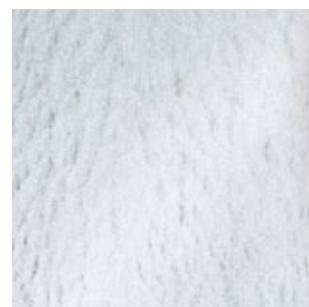

Cattedrale bianco  
"Cattedrale" white glass



Stirato bianco  
"Stirato" white glass



Stirato giallo  
"Stirato" yellow glass

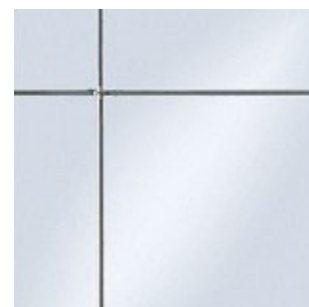

Legato Piombo  
Leaded glass

## Le Cerniere - The Hinges

Cerniera in Stile,  
a pomella in ferro  
Old fashioned pintel  
hinge in iron



Finitura brunita  
Burnished finish

## Capitelli e coprifili - Doorheads and casings

Le porte Arte Povera vengono fornite complete di coprifili a 90°. Capitelli e coprifili speciali disponibili a richiesta. Vedi anche approfondimento Sezione Capitelli pag. 370.

The Arte Povera doors are supplied with casings, 90° cut. Doorheads and special casings available upon request. See also the detailed section of doorheads and casings at page 370.



Coprifili a 90°  
Casings 90° cut

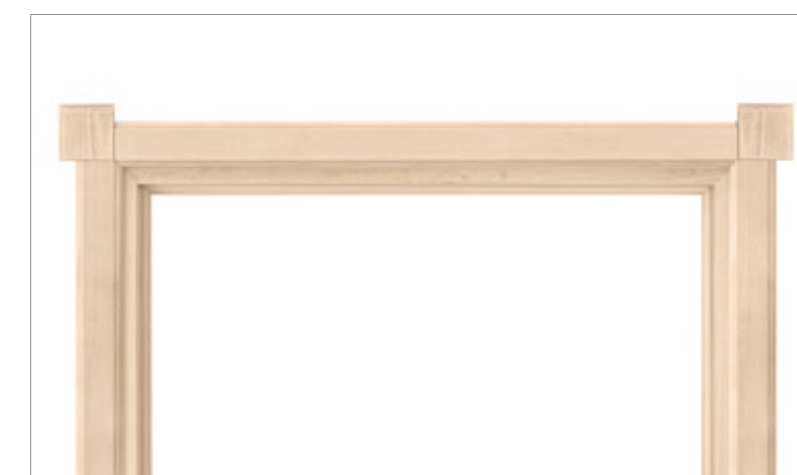

Coprifili con blocchetti semplici  
Casings with simple corner blocks



Coprifili con blocchetti torniti  
Casings with turned corner blocks

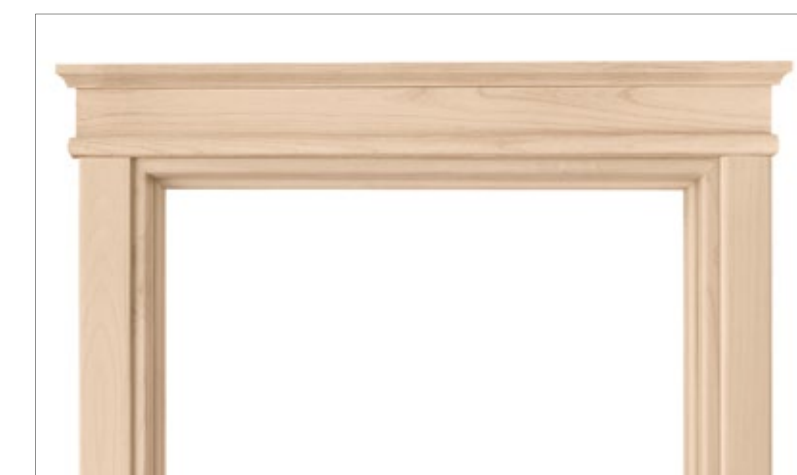

Capitello Lineare  
Flat doorhead





*Roviniò*





# Roviniò

La suggestione del vissuto, l'inevitabile fascino emanato dal tempo che lascia il suo segno. Regalando un effetto che va oltre il bello. Un effetto ottenuto grazie alla straordinaria manualità di esperti artigiani, in grado di creare effetti che colpiscono occhi e trasportano emozioni. La verniciatura al mallo di noce completa l'opera con un tocco di ulteriore sapienza.

The idea of having lived, the unavoidable charm exhaled by a time that leaves its mark, offering an effect that goes beyond beauty alone. An aged look effect which is achieved through the skilled handwork of expert craftsmen, who are able to create eye-catching impressions and emotional inspiration. Walnut husk painting completes the work with a further touch of wisdom.

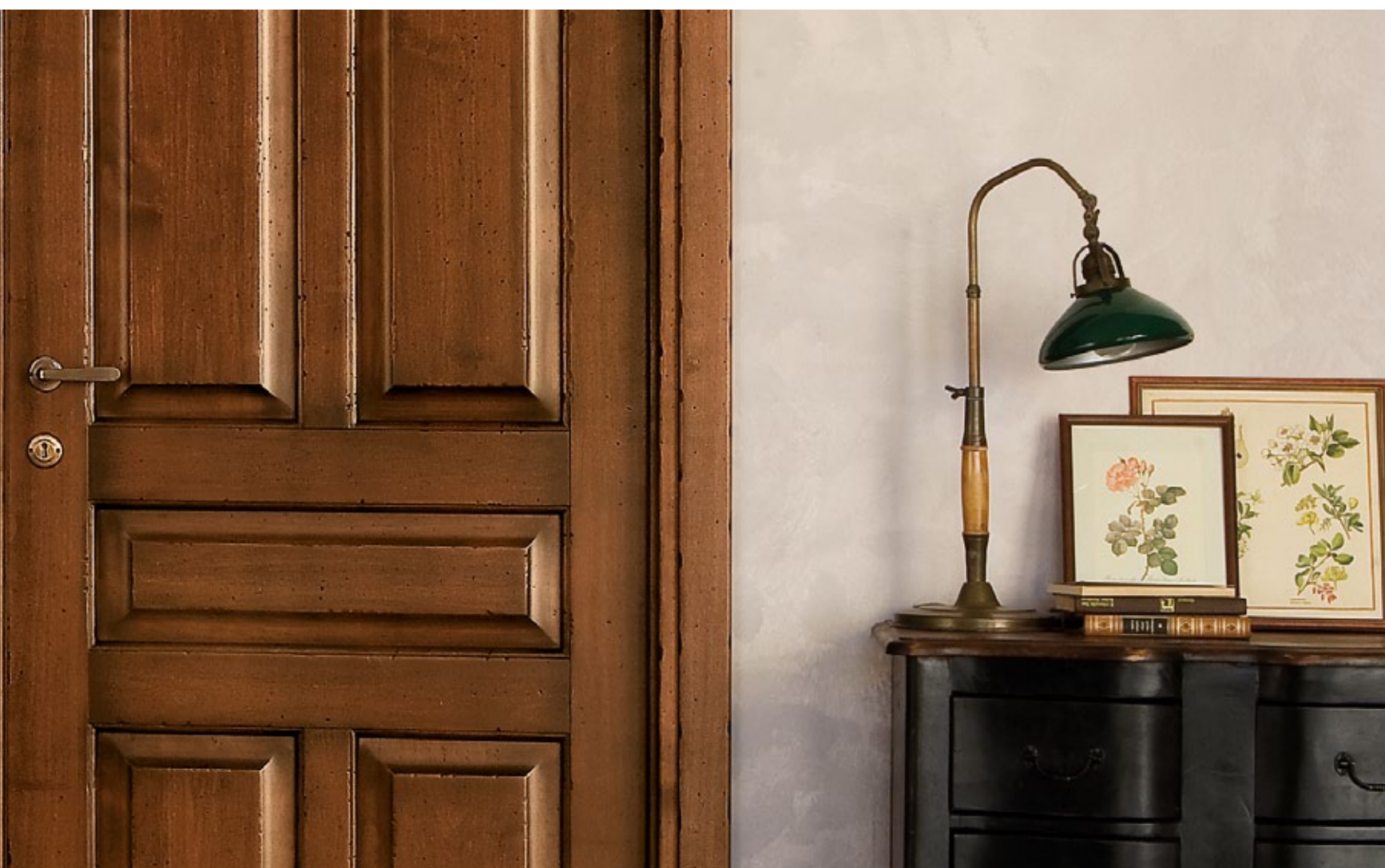

cod. 5-40 Alder anticato noce scuro - coprifili lisci.

code 5-40 Alder stained antique dark walnut - smooth casings.

# Roviniò

legnoform





cod. 5-50 Alder anticato noce scuro - capitello lineare coprifili lisci.

code 5-50 Alder stained antique dark walnut - Flat doorhead with smooth casings.



cod. 2-11 Alder anticato noce scuro coprifili lisci.

code 2-11 Alder stained antique dark walnut smooth casings.



cod. 2-19 Alder anticato noce scuro - cristalli satinati bianchi - bisello lucido, coprifili lisci.

code 2-19 Alder stained antique dark walnut white satin clear bevelled glass, smooth casings.

Rovinio





cod. 4T-32 Alder anticato noce  
scuro - capitello lineare  
coprifili lisci.

code 4T-32 Alder stained antique  
dark walnut - Flat doorhead and  
smooth casings.



Rovinio

legnoform





cod. 3-14 Alder anticato noce scuro - capitello centinato coprifili lisci.

code 3-14 Alder stained antique dark walnut - Bowed doorhead with smooth casings.



cod. 3-16 Alder anticato noce scuro cristallo cattedrale, coprifili lisci.

code 3-16 Alder stained antique dark walnut "cattedrale" glass - smooth casings.



cod. 3-11 Alder anticato noce scuro coprifili lisci.

code 3-11 Alder stained antique dark walnut smooth casings.

Rovinio

legnoform



# Le Soluzioni The Solutions

Immagina la porta dei tuoi desideri. Immaginala in casa tua, in un ambiente dove vivere una quotidianità piacevole, appagante, di stile. E immaginala esattamente come vuoi, perché qualunque sia la sua forma, possiamo realizzarla. Grazie alla maestria artigiana Legnoform, sono disponibili soluzioni speciali che consentono di realizzare ogni tua esigenza, con interventi unici realmente a misura di desiderio. Il tuo.

Imagine the door of your wish. Imagine it in your own home, a surrounding in which you can live a gratifying, pleasant and stylish everyday life. And imagine it exactly as you wish and with whatever shape, we can produce it. Legnoform's masterful craftsmanship will allow you to have special solutions uniquely tailored to a wish – your very own.

Alcuni esempi di soluzioni speciali - Some examples of special solutions

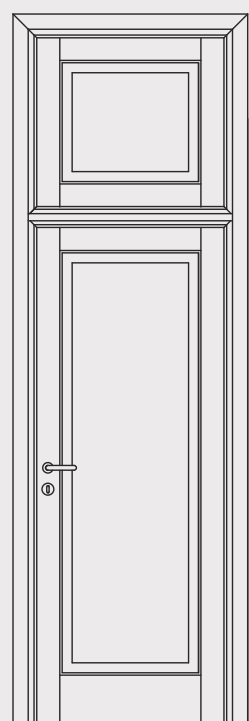

Sopraluce con battente  
Transom with doorleaf

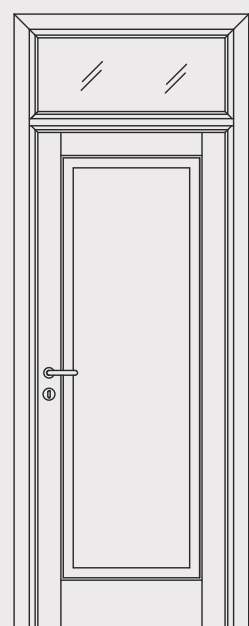

Sopraluce a vetro  
Transom window

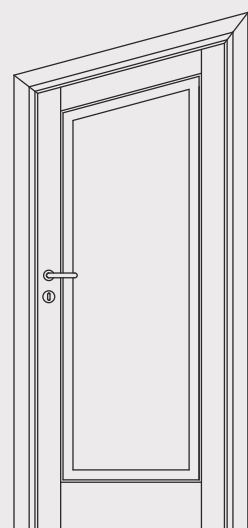

Porta obliqua  
Oblique door

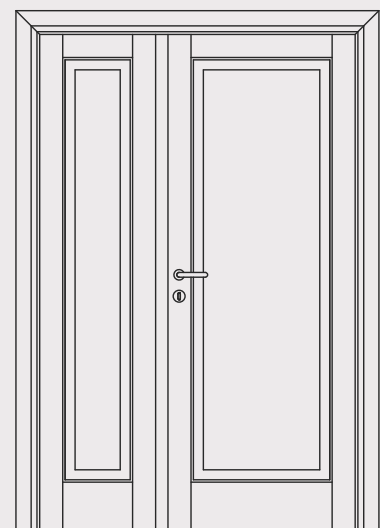

Doppia asimmetrica  
Asymmetrical double door



Rovinio



# Rovinò

Porte in legno massello di Nocino Americano - Alder con effetto usurato dal tempo. Ogni modello è disponibile nella versione a 2 battenti e predisposto per vetro. Coprifili lisci, taglio a 45°.

Solid wood Alder doors, with distressed finish. Each model is available in the double door version and can be fitted with glass. Smooth casings, 45° cut.

## I Modelli - The Models

La lavorazione Rovinò è realizzabile su tutte le Serie Legnoform.  
The Rovinò finish is available on all Legnoform's Series.

## Le Finiture Legno - The Wood Finishes



Alder anticato noce scuro  
Alder stained antique dark walnut

## I Cristalli - The Glass



Satinato bianco - bisello lucido  
White satin clear bevelled glass

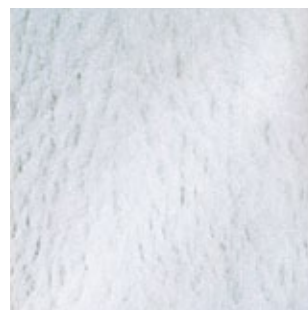

Cattedrale bianco  
"Cattedrale" white glass



Stirato bianco  
"Stirato" white glass



Legato piombo  
Leaded glass

## Le Cerniere - The Hinges

Cerniera in Stile,  
a pomella in ferro  
Old fashioned pintel  
hinge in iron



Finitura brunita  
Burnished finish

## Capitelli e coprifili - Doorheads and casings

Le porte Rovinò vengono fornite complete di coprifili lisci, taglio a 45°. Capitelli e coprifili speciali disponibili a richiesta. Vedi anche approfondimento Sezione Capitelli pag. 370.

The Rovinò doors are supplied with smooth casings, 45° cut. Doorheads and special casings available upon request. See also the detailed section of doorheads and casings at page 370.



Coprifili lisci  
Smooth casings



Capitello Centinato con coprifili lisci  
Bowed doorhead with smooth casings



Capitello Lineare con coprifili lisci  
Flat doorhead with smooth casings



Capitello Lineare con rosette con coprifili lisci  
Flat doorhead with turned blocks - smooth casings







## *Classici Classici e Anticati*

Modelli classici, della tradizione, che spaziano da forme rettangolari fino a quelle ad arco, frutto della grande maestria artigiana Legnoform.

Classical models, belonging to the tradition, going from rectangular till arched doors, brainchild of Legnoform's great craftsmanship.





*Classici e Anticati*



# Classici e Anticati

Un capolavoro che evolve nel tempo, arricchendosi ma rimanendo fedele a se stesso. Da oltre 20 anni la Collezione "Falegnameria Classica" è costantemente al centro del prezioso mondo Legnoform: negli anni ha saputo rinnovarsi, ha introdotto modelli innovativi come le porte centinate con telaio rettangolare. Disponibili sia in Alder che in Rovere, tutte le creazioni possono avere finiture classiche o, in alternativa, raffinate finiture anticate.

A masterpiece evolving through time, self-enriching, yet staying faithful to itself.

For over 20 years the "Falegnameria Classica" collection has constantly been the centrepiece of the Legnoform world: it has been able to renew itself and introduce new innovative models such as curved doors with rectangular frames. Available both in Alder and Oak, all models can be finished in classical colours and, alternatively, in refined antique finishes.

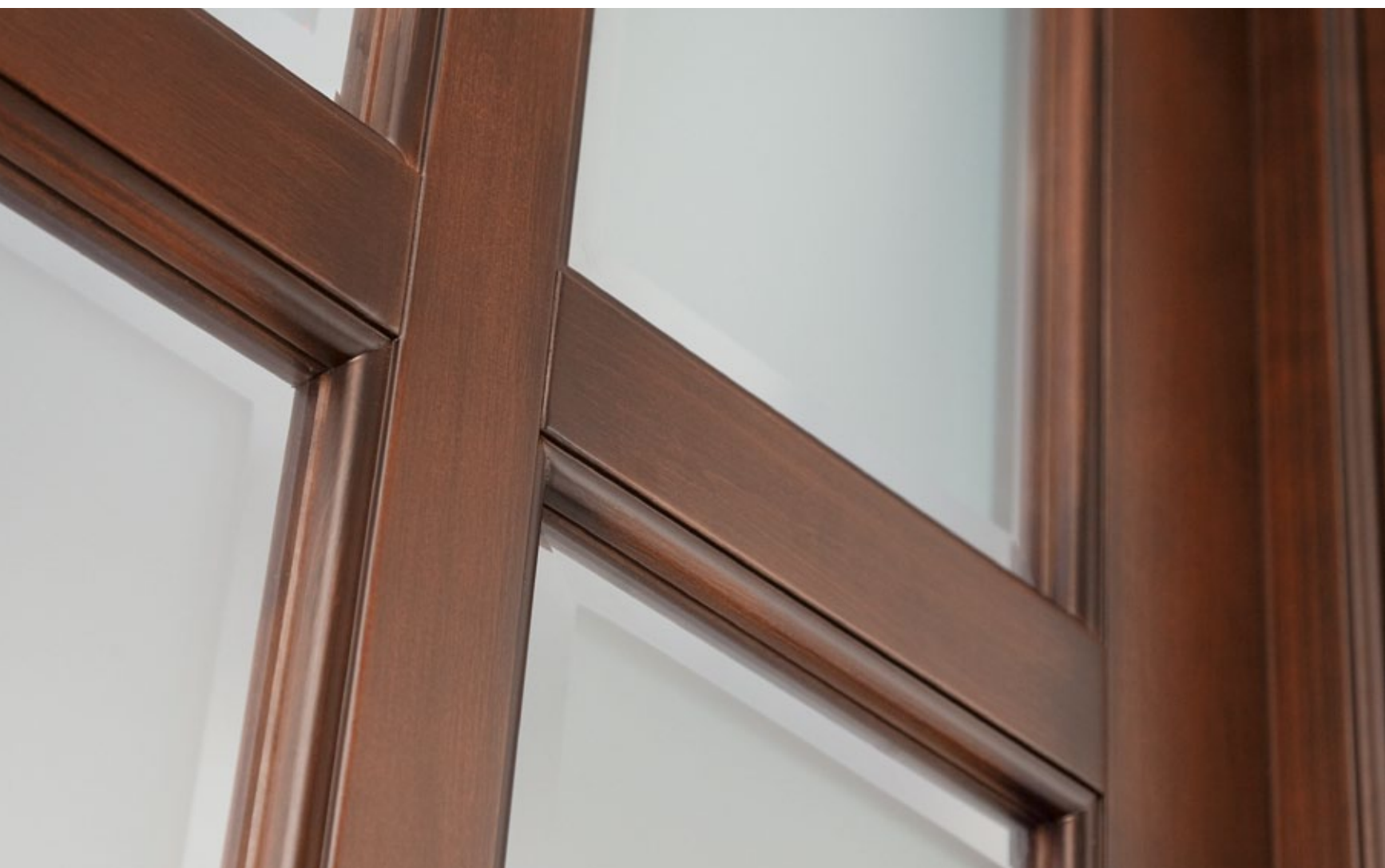

cod. 1-22 Alder anticato noce scuro, cristalli satinati bianchi bisello lucido - coprifili lisci.

code 1-22 Alder stained antique dark walnut, white satin clear bevelled glass - smooth casings.

*Serie 100*

**legnoform**

*Classici e Anticati*





cod. 1-25 Alder anticato noce chiaro, cristalli satinati bianchi bisello lucido - coprifili lisci.

code 1-25 Alder stained antique light walnut, white satin clear bevelled glass - smooth casings.



cod. 1-15 Alder anticato noce scuro - coprifili lisci.

code 1-15 Alder stained antique dark walnut - smooth casings.



cod. 1-35 Alder anticato noce chiaro - coprifili lisci.

code 1-35 Alder stained antique light walnut - smooth casings.

*Classici e Anticati*

*Serie 100*

**legnoform**





cod. 1-11 Alder anticato noce scuro - coprifili lisci.

code 1-11 Alder stained antique dark walnut - smooth casings.



cod. 1-34 Rovere anticato fondo scuro - coprifili lisci.

code 1-34 Oak stained antique dark base - smooth casings.



cod. 1-32 Alder tinto ciliegio scuro - coprifili lisci.

code 1-32 Alder stained dark cherry - smooth casings.

*Classici e Anticati*

*Serie 100*

**legnoform**





cod. 2-14 Alder tinto noce scuro  
coprifili standard.

code 2-14 Alder stained dark  
walnut - standard casings.



cod. 2-20 Alder anticato noce scuro - cristalli satinati bianchi,  
bisello lucido - coprifili standard.

code 2-20 Alder stained antique dark walnut - white satin clear bevelled  
glass - standard casings.



cod. 2-14 Alder anticato noce  
chiaro - capitello Barocco  
coprifili mod.mensola liscia e  
zoccolino.

code 2-14 Alder stained antique  
light walnut - "Barocco" doorhead  
with casings mod. Smooth corbel  
and plinth.

*Classici e Anticati*

*Serie 200*

**legnoform**





cod. 2-13 Alder tinto noce chiaro, cristallo inciso all'Inglese, coprifili con angoli arrotondati.

code 2-13 Alder stained light walnut, bevel glass detail section, casings with rounded corners.



cod. 2-14 Alder tinto ciliegio chiaro - coprifili standard.

code 2-14 Alder stained light cherry - standard casings.



cod. 2-35 Alder tinto ciliegio chiaro, porta doppio battente con cristalli satinati bianchi, bisello lucido - coprifili standard.

code 2-35 Alder stained light cherry, double-leaf door with white satin, clear bevelled glass - standard casings.

*Classici e Anticati*

*Serie 200*

**legnoform**





cod. 3-16 Alder anticato noce chiaro, cristalli satinati bianchi  
bisello lucido - capitello lineare con rosette - coprifili standard.

code 3-16 Alder stained antique light walnut, white satin clear  
bevelled glass - Flat doorhead with turned blocks - standard casings.



cod. 3-14 Rovere tinto noce scuro  
coprifili standard.

code 3-14 Oak stained dark walnut  
standard casings.



*Serie 300*

cod. 3-14 Rovere tinto noce chiaro - coprifili standard / code 3-14 Oak stained light walnut - standard casings.

*Classici e Anticati*





cod. 4T-13 Alder tinto noce chiaro - cristallo doppio legato  
ottone - capitello lineare coprifili standard.

code 4T-13 Alder stained light walnut - double brass beading  
glass - Flat doorhead standard casings.



cod. 4T-31 Alder anticato noce scuro - capitello  
timpano interrotto - coprifili standard.

code 4T-31 Alder stained antique dark walnut - Broken  
gable doorhead - standard casings.



cod. 4T-14 Alder anticato noce scuro, capitello timpano interrotto, coprifili standard / code 4T-14 Alder stained antique dark walnut - Broken gable doorhead, standard casings.

*Classici e Anticati*

*Serie 400*





cod. 5-30 Rovere anticato fondo  
chiaro - coprifili standard.  
code 5-30 Oak stained antique  
light base - standard casings.



cod. 5-31 Rovere anticato fondo  
chiaro - coprifili standard.  
code 5-31 Oak stained antique  
light base - standard casings.



cod. 5-40 Rovere anticato fondo  
chiaro - coprifili standard.  
code 5-40 Oak stained antique  
light base - standard casings.

*Classici e Anticati*

*Serie 500*

**legnoform**





cod. 5-32 Rovere anticato fondo scuro - coprifili standard.

code 5-32 Oak stained antique dark base - standard casings.



cod. 5-30 Rovere anticato fondo scuro - coprifili standard.

code 5-30 Oak stained antique dark base - standard casings.



cod. 5-30 Rovere anticato fondo scuro, porta doppio battente coprifili standard.

code 5-30 Oak stained antique dark base, double-leaf door standard casings.

*Classici e Anticati*

*Serie 500*

**legnoform**





cod. 5-31 Alder tinto noce scuro  
coprifili standard.

code 5-31 Alder stained dark  
walnut - standard casings.



cod. 5-30 Alder tinto noce chiaro - capitello  
timpano interrotto, coprifili standard.

code 5-30 Alder stained light walnut - Broken gable  
doorhead - standard casings.



cod. 5-32 Alder anticato noce  
scuro/profili argento - capitello  
lineare, coprifili standard.

code 5-32 Alder stained antique  
dark walnut/silver profiles - Flat  
doorhead, standard casings.

*Classici e Anticati*

*Serie 500*

**legnoform**





cod. 6-17 Alder anticato noce scuro/profilo oro - capitello centinato, coprifili standard.

code 6-17 Alder stained antique dark walnut/gold profiles - Bowed doorhead, standard casings.



*Serie 600*

cod. 6-14 Alder anticato noce scuro - capitello lineare, coprifili standard / code 6-14 Alder stained antique dark walnut - Flat doorhead standard casings.

*Classici e Anticati*



Una finitura dall'incantevole leggerezza, ottenuta con uno speciale trattamento che riproduce l'invecchiamento del legno sopra una base chiara. Il successivo trattamento con calce e gesso schiarisce la porosità del massello.

A delightful finish obtained by a special treatment that replicates the ageing process in wood on a light base. A second coat of lime and chalk makes the pores in the solid wood look clearer.



cod. 6-17 Rovere anticato poro bianco - capitello centinato, coprifili standard.

code 6-17 Oak stained antique white pore - Bowed doorhead, standard casings.

*Classici e Anticati*

*Serie 600*

**legnoform**





cod. 6-30 Alder anticato noce chiaro, porta doppio battente con cristalli legati ottone - capitello lineare, coprifili standard.

code 6-30 Alder stained antique light walnut, double-leaf door with brass beading glass - Flat doorhead, standard casings.



cod. 6-16 Alder anticato noce chiaro, cristalli satinati bianchi bisello lucido, coprifili standard.

code 6-16 Alder stained antique light walnut - white satin clear bevelled glass, standard casings.



cod. 6-17 Alder tinto ciliegio scuro coprifili standard.

code 6-17 Alder stained dark cherry standard casings.

*Classici e Anticati*

*Serie 600*

**legnoform**



cod. 7-13 Alder anticato noce  
chiaro, cristallo legato ottone  
capitello lineare, coprifili  
standard.

code 7-13 Alder stained antique  
light walnut, brass beading glass  
Flat doorhead, standard casings.



cod. 7-14 Alder tinto noce chiaro  
coprifili standard.

code 7-14 Alder stained light  
walnut - standard casings.



*Classici e Anticati*

*Serie 700*

**legnoform**



cod. 7-14 Alder anticato noce  
scuro - capitello timpano  
interrotto, coprifili standard.

code 7-14 Alder stained antique  
dark walnut - Broken gable  
doorhead standard casings.



cod. 7-30 Rovere tinto noce scuro, porta doppio battente con  
cristalli legato ottone, coprifili con angoli arrotondati.

code 7-30 Oak stained dark walnut, double-leaf door with brass  
beading glass, casings with rounded corners.

*Classici e Anticati*

*Serie 700*

**legnoform**



Porte che realizzano un desiderio, andando oltre la forma, oltrepassando i limiti strutturali: perchè le Serie 700 e 800 Rettangolari consentono di installare una porta dal profilo centinato su un normale telaio rettangolare, senza alcuna modifica muraria. Capolavori dedicati a chi ama la sinuosità e l'eleganza di un grande classico.

Doors that make wishes come true, surpassing shape and structural limits: for the Serie 700 and 800 Rectangular allow a curved door to be fitted within a normal rectangular frame, without any construction work. Masterpieces dedicated to those who love the slinky elegance of a great classic.

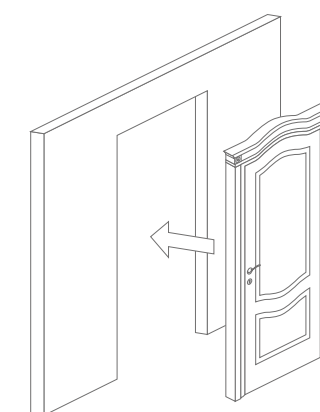

cod. 7R-17 Alder anticato noce scuro/profili oro – capitello 700R, coprifili lisci.

code 7R-17 Alder stained antique dark walnut/gold profiles – 700R doorhead, smooth casings.

*Classici e Anticati*

*Serie 700R*

**legnoform**





cod. 7R-37 Alder anticato noce chiaro, porta a doppio battente con capitello 700R, coprifili lisci.

code 7R-37 Alder stained antique light walnut, double-leaf door with 700R doorhead, smooth casings.



cod. 7R-14 Alder anticato noce chiaro - capitello 700R, coprifili lisci.

code 7R-14 Alder stained antique light walnut - 700R doorhead, smooth casings.



cod. 7R-13 Alder anticato noce chiaro, cristallo legato ottone - capitello 700R, coprifili lisci.

code 7R-13 Alder stained antique light walnut, brass beading glass - 700R doorhead, smooth casings.

*Classici e Anticati*

*Serie 700R*

**legnoform**



cod. 7R-17 Alder anticato noce  
scuro - capitello 700R, coprifili  
lisci.

code 7R-17 Alder stained antique  
dark walnut - 700R doorhead,  
smooth casings.



cod. 7R-17 Alder tinto mogano - capitello  
700R, coprifili lisci.

code 7R-17 Alder stained mahogany - 700R  
doorhead, smooth casings.



cod. 7R-13 Alder anticato noce scuro, cristallo legato  
ottone - capitello 700R, coprifili lisci.

code 7R-13 Alder stained antique dark walnut, brass  
beading glass - 700R doorhead, smooth casings.

*Classici e Anticati*

*Serie 700R*

**legnoform**





*Serie 800 Rettangolare*



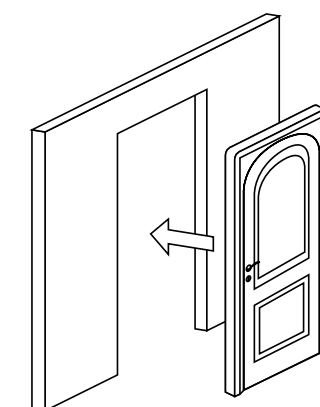

cod. 8R-14 Alder anticato noce  
chiaro - coprifili con angoli  
arrotondati.

code 8R-14 Alder stained antique  
light walnut - casings with  
rounded corners.

*Classici e Anticati*

*Serie 800R*

**legnoform**





cod. 8R-30 Alder tinto ciliegio scuro, porta doppio battente con cristalli legati ottone, coprifili con angoli arrotondati.

code 8R-30 Alder stained dark cherry, double-leaf door with brass beading glass - casings with rounded corners.



cod. 8R-14 Alder anticato noce scuro - capitello lineare con rosette, coprifili standard.

code 8R-14 Alder stained antique dark walnut - Flat doorhead with turned blocks, standard casings.

*Classici e Anticati*

*Serie 800R*

**legnoform**



Una linea sinuosa che si sospende nello spazio non statico, diventando chiave di volta di un ambiente. Liberando la creatività, attorno cui interpretare i propri gusti. Le Serie 800 e 900 esaltano tutta l'abilità manuale degli artigiani Legnoform, in grado di plasmare il prezioso legno massello, costruendone eleganti tondità.

A slinky line suspended in dynamic space, and becoming the keystone of all that surrounds it. Creativity is freed up to interpret your own tastes. The Serie 800 and 900 enhance the skills of Legnoform's craftsmen, who are able to model rich solid wood into elegant roundness.



cod. 8-11 Alder anticato noce  
chiaro - coprifili standard.

code 8-11 Alder stained antique  
light walnut - standard casings.

*Classici e Anticati*

*Serie 800*

**legnoform**





cod. 8-13 Alder anticato noce  
chiaro - cristallo legato ottone  
coprifili standard.

code 8-13 Alder stained antique  
light walnut - brass beading glass  
standard casings.



cod. 8-32 Rovere anticato fondo scuro, porta doppio battente  
con coprifili standard.

code 8-32 Oak stained antique dark base, double-leaf door with  
standard casings.

*Classici e Anticati*

*Serie 800*

**legnoform**





cod. 9-30 Alder tinto noce chiaro, porta doppio battente con cristalli legati ottone - coprifili standard.

code 9-30 Alder stained light walnut, double-leaf door with brass beading glass - standard casings.



cod. 9-14 Rovere tinto noce chiaro - coprifili standard.

code 9-14 Oak stained light walnut standard casings.

*Classici e Anticati*

*Serie 900*

**legnoform**



# Le Soluzioni *The Solutions*

Immagina la porta dei tuoi desideri. Immaginala in casa tua, in un ambiente dove vivere una quotidianità piacevole, appagante, di stile. E immaginala esattamente come vuoi, perché qualunque sia la sua forma, possiamo realizzarla. Grazie alla maestria artigiana Legnoform, sono disponibili soluzioni speciali che consentono di realizzare ogni tua esigenza, con interventi unici realmente a misura di desiderio. Il tuo.

Imagine the door of your wish. Imagine it in your own home, a surrounding in which you can live a gratifying, pleasant and stylish everyday life. And imagine it exactly as you wish and with whatever shape, we can produce it. Legnoform's masterful craftsmanship will allow you to have special solutions uniquely tailored to a wish – your very own.



Fuori misura - non standard measures

## Alcuni esempi di soluzioni speciali Some examples of special solutions

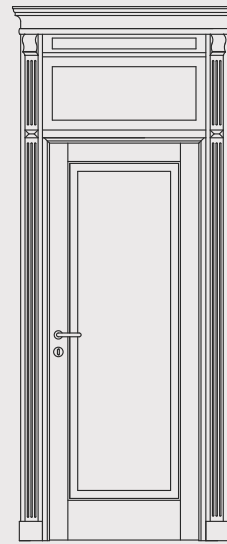

Chiambrana  
"Chiambrana"

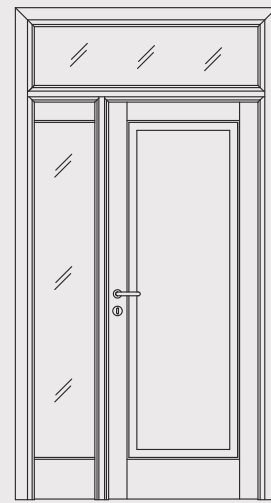

Fianco-luce e sopra-luce  
Sidelight with transom window

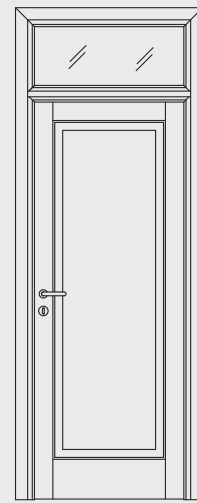

Sopraluce a vetro  
Transom window



Porta fuori misura in altezza  
cod. 5-30 Alder anticato noce  
chiaro, capitello timpano  
coprifili mod. mensola liscia e  
zoccolino.

Special Height door code 5-30 Alder  
stained antique light walnut  
Gable doorhead, casings mod.  
Smooth corbel and plinth.



# IModelli The Models

## Serie 100



cod. 1-11   cod. 1-21   cod. 1-14   cod. 1-24   cod. 1-15   cod. 1-25   cod. 1-32   cod. 1-42   cod. 1-34   cod. 1-44   cod. 1-35

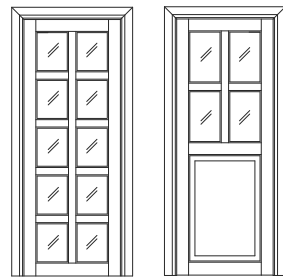

cod. 1-45   cod. 1-22

## Serie 200



cod. 2-11   cod. 2-12   cod. 2-21   cod. 2-14   cod. 2-13   cod. 2-15   cod. 2-19   cod. 2-22   cod. 2-20

## Serie 300

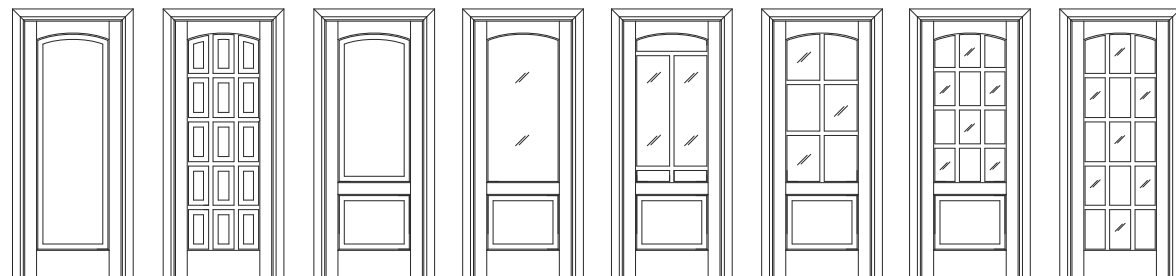

cod. 3-11   cod. 3-21   cod. 3-14   cod. 3-13   cod. 3-15   cod. 3-16   cod. 3-19   cod. 3-20

## Serie 400

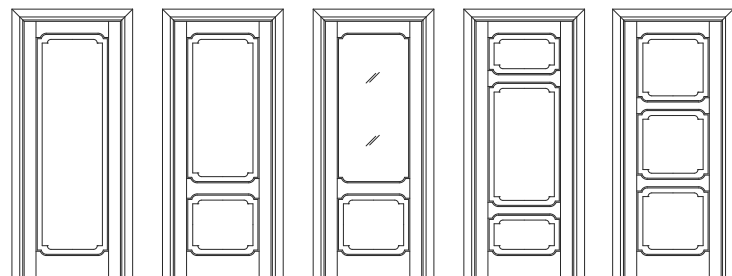

cod. 4T-11   cod. 4T-14   cod. 4T-13   cod. 4T-31   cod. 4T-32

## Serie 500

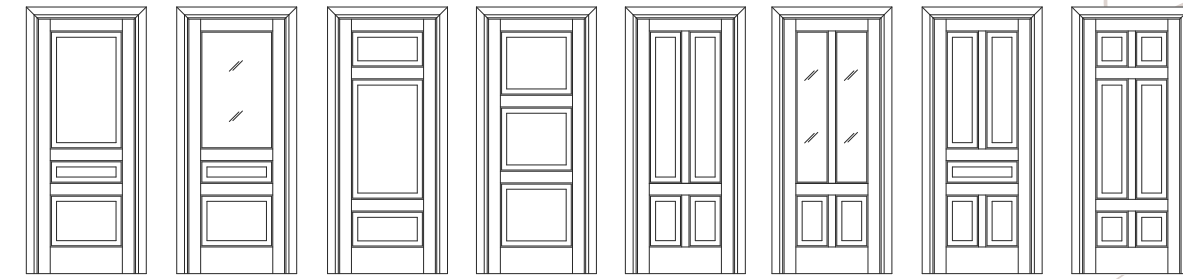

cod. 5-30   cod. 5-34   cod. 5-31   cod. 5-32   cod. 5-40   cod. 5-44   cod. 5-50   cod. 5-60

## Serie 600

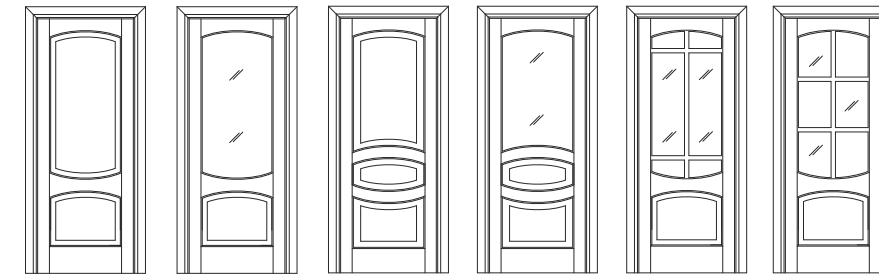

cod. 6-14   cod. 6-13   cod. 6-17   cod. 6-18   cod. 6-15   cod. 6-16

## Serie 700

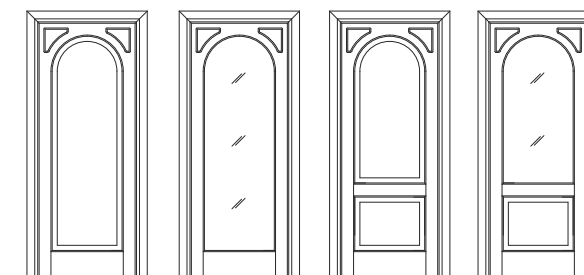

cod. 7-11   cod. 7-12   cod. 7-14   cod. 7-13

## Serie 700 Rettangolare

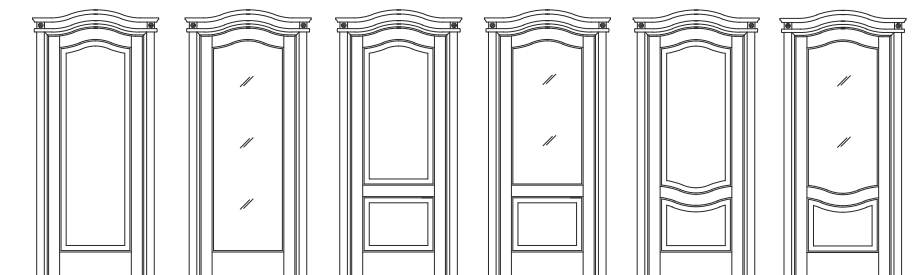

cod. 7R-11   cod. 7R-12   cod. 7R-14   cod. 7R-13   cod. 7R-17   cod. 7R-18

## Serie 800

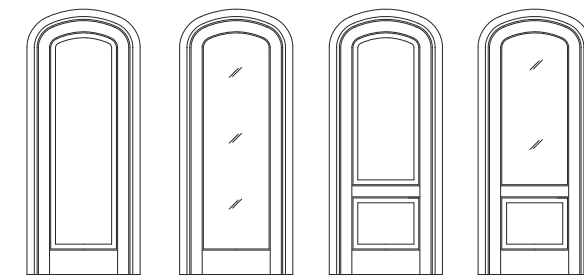

cod. 8-11   cod. 8-12   cod. 8-14   cod. 8-13

## Serie 800 Rettangolare

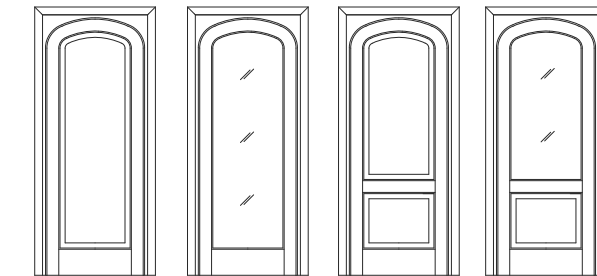

cod. 8R-11   cod. 8R-12   cod. 8R-14   cod. 8R-13

## Serie 900

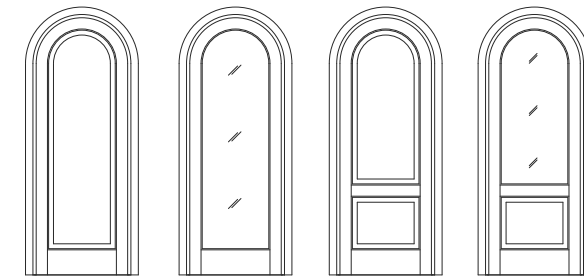

cod. 9-11   cod. 9-12   cod. 9-14   cod. 9-13





# Classici e Anticati

Porte in legno massello di Nocino Americano - Alder o Rovere. Ogni modello è disponibile nella versione a 2 battenti e predisposto per vetro. Coprifili standard a 45°.

Solid wood doors in Alder or Oak. Each model is available in the double-door version and can be fitted with glass. Standard 45° casings.

## Le Finiture Classiche - The Classical Finishes

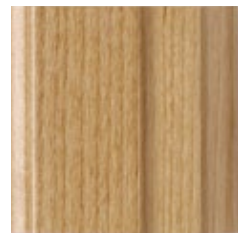

Alder tinto naturale  
Alder stained natural

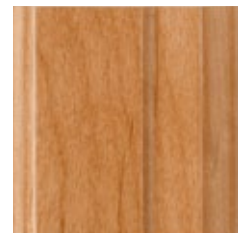

Alder tinto ciliegio chiaro  
Alder stained light cherry

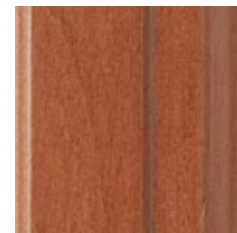

Alder tinto ciliegio scuro  
Alder stained dark cherry

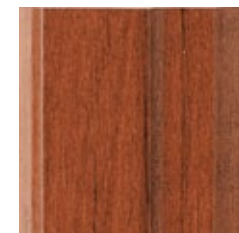

Alder tinto mogano  
Alder stained mahogany

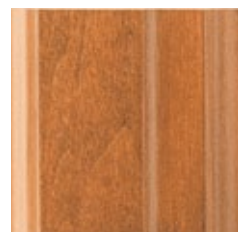

Alder tinto noce chiaro  
Alder stained light walnut

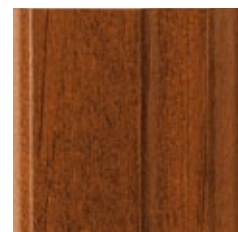

Alder tinto noce scuro  
Alder stained dark walnut

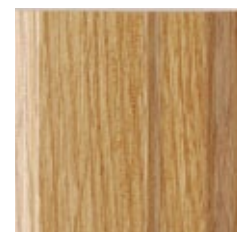

Rovere tinto noce chiaro  
Oak stained light walnut

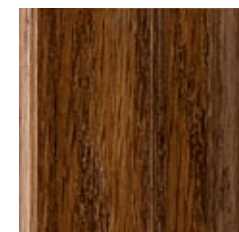

Rovere tinto noce scuro  
Oak stained dark walnut

## Le Finiture Anticate - The Antique Finishes



Alder anticato noce chiaro  
Alder stained antique light walnut



Alder anticato noce scuro  
Alder stained antique dark walnut



Rovere anticato fondo chiaro  
Oak stained antique light base



Rovere anticato fondo scuro  
Oak stained antique dark base



Rovere anticato poro bianco  
Oak stained antique white pore

## I Cristalli - The Glass

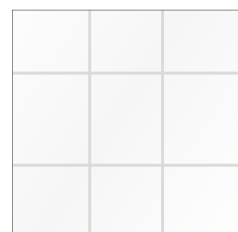

Inciso all'inglese, satinato bianco - bisello lucido  
Bevel detail section, white satin clear bevelled

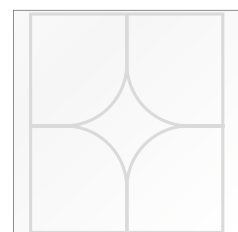

Inciso a stella, satinato bianco bisello lucido  
Bevel detail star, white satin clear bevelled



Inciso disegno legato, satinato bianco - bisello lucido  
Bevel detail like brass beading, white satin clear bevelled

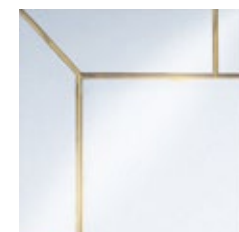

Legato ottone satinato bianco bisello lucido  
White satin - clear bevelled with brass beading



Doppio legato ottone satinato bianco/bronzo  
Satin white/bronze with double antique brass beading

## Le Cerniere - The Hinges

Cerniera mod. Classico, a pomella, in ottone  
Pintel hinge, mod. Classical, in brass



Finitura ottone satinato  
Mat brass finish



Finitura ottone lucido  
Polished brass finish

## Capitelli e coprifili - Doorheads and casings

Le porte Classici e Anticati vengono fornite complete di coprifili standard a 45°. Capitelli e coprifili speciali disponibili a richiesta. Vedi anche approfondimento Sezione Capitelli pag. 370.

The Classici e Anticati doors are supplied with standard 45° casings. Doorheads and special casings available upon request. See also the detailed section of doorheads and casings at page 370.



Coprifili standard  
Standard casings



Capitello Lineare con coprifili standard  
Flat doorhead with standard casings



Capitello Lineare con rosette con coprifili standard  
Flat doorhead with turned blocks and standard casings



Capitello Centinato con coprifili standard  
Bowed doorhead with standard casings



Capitello a Timpano con coprifili standard  
Gable doorhead with standard casings



Capitello Quadrato con coprifili mod. Bastoncino rigato  
Square doorhead with casings mod. Striped strip



Capitello Timpano interrotto - coprifili mod. Mensola liscia  
Broken gable doorhead with casings mod. Smooth corbel



Capitello Timpano con coprifili mod. Mensola rigata  
Gable doorhead with casings mod. Striped corbel



Capitello Lineare con coprifili mod. Bastoncino rigato  
Flat doorhead with casings mod. Striped strip





# *Capitelli e Coprifili*

Un'ampia gamma di Capitelli e Coprifili disponibili a scelta per rendere ancora più uniche le vostre porte.

# *Doorheads and Casings*

A wide range of doorheads and casings, available upon request, to make your doors even more unique.



# Capitelli e Coprifili

Le porte Legnoform si arricchiscono di preziosi capitelli abbinabili a coprifili standard/lisci o a coprifili speciali disponibili in 4 modelli, completi di zoccolino.

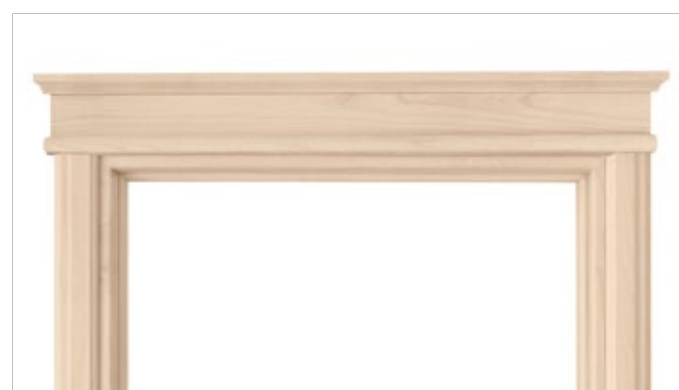

cm 6,4

**Capitello Lineare con coprifili standard**  
Flat doorhead with standard casings

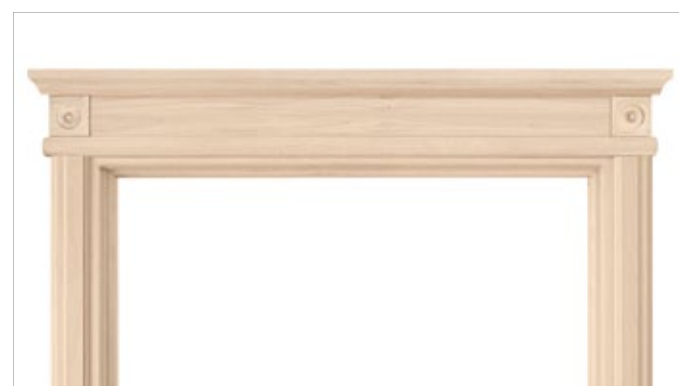

cm 6,4

**Capitello Lineare con rosette con coprifili standard**  
Flat doorhead with turned blocks with standard casings



cm 6,4

**Capitello Centinato con coprifili standard**  
Bowed doorhead with standard casings

# Doorheads and Casings

Legnoform doors can be further enriched by precious doorheads supplied with standard/smooth casings or with special ones available in 4 different models, with plinth.

Varianti Capitello con coprifili speciali L. cm 11,5 completi di zoccolino  
Doorheads' variant with special casings 11,5 cm wide, with plinth



cm 11,5

**Bastoncino liscio (11,5 cm)**  
Smooth strip (11,5 cm)



**Bastoncino rigato (11,5 cm)**  
Striped strip (11,5 cm)



**Mensola liscia (11,5 cm)**  
Smooth corbel (11,5 cm)



**Mensola rigata (11,5 cm)**  
Striped corbel (11,5 cm)



cm 11,5

**Bastoncino liscio (11,5 cm)**  
Smooth strip (11,5 cm)



**Bastoncino rigato (11,5 cm)**  
Striped strip (11,5 cm)



**Mensola liscia (11,5 cm)**  
Smooth corbel (11,5 cm)



**Mensola rigata (11,5 cm)**  
Striped corbel (11,5 cm)



cm 11,5

**Bastoncino liscio (11,5 cm)**  
Smooth strip (11,5 cm)



**Bastoncino rigato (11,5 cm)**  
Striped strip (11,5 cm)



**Mensola liscia (11,5 cm)**  
Smooth corbel (11,5 cm)



**Mensola rigata (11,5 cm)**  
Striped corbel (11,5 cm)





cm 6,4

**Capitello a Timpano con coprifili standard**  
Gable doorhead with standard casings



cm 6,4

**Capitello a Timpano interrotto con coprifili standard**  
Broken gable doorhead with standard casings

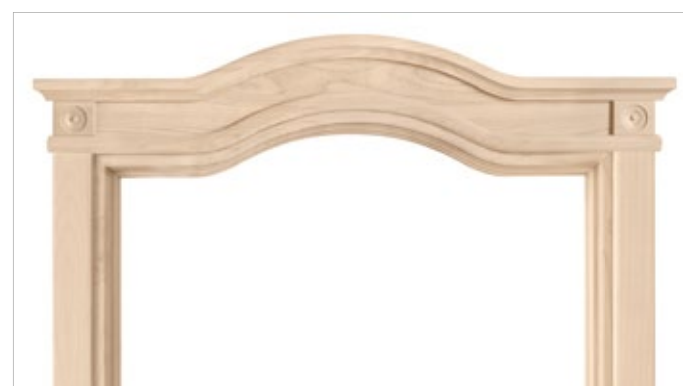

cm 6,4

**Capitello 700R con coprifili lisci** Disponibile solo per la Serie 700R  
Doorhead Serie 700R with smooth casings Available only on the serie 700R

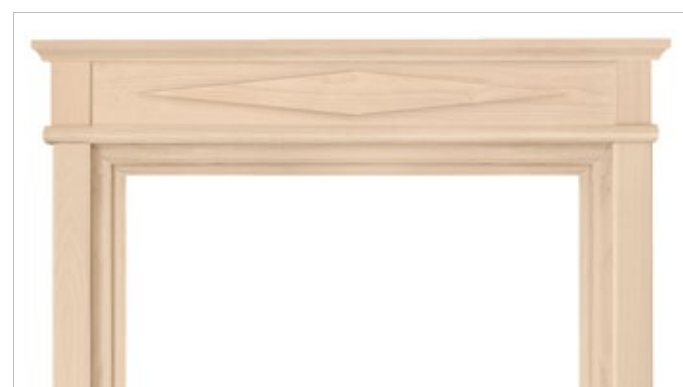

cm 6,4

**Capitello Rombi con coprifili lisci**  
"Rombi" doorhead with smooth casings

Zoccolino  
Plinth

**Varianti Capitello con coprifili speciali L. cm 11,5 completi di zoccolino**  
Doorheads' variant with special casings 11,5 cm wide, with plinth



cm 11,5

**Bastoncino liscio (11,5 cm)**  
Smooth strip (11,5 cm)



**Bastoncino rigato (11,5 cm)**  
Striped strip (11,5 cm)



**Mensola liscia (11,5 cm)**  
Smooth corbel (11,5 cm)



**Mensola rigata (11,5 cm)**  
Striped corbel (11,5 cm)



cm 11,5

**Bastoncino liscio (11,5 cm)**  
Smooth strip (11,5 cm)



**Bastoncino rigato (11,5 cm)**  
Striped strip (11,5 cm)



**Mensola liscia (11,5 cm)**  
Smooth corbel (11,5 cm)



**Mensola rigata (11,5 cm)**  
Striped corbel (11,5 cm)



cm 11,5

**Bastoncino liscio (11,5 cm)**  
Smooth strip (11,5 cm)



**Bastoncino rigato (11,5 cm)**  
Striped strip (11,5 cm)



**Mensola liscia (11,5 cm)**  
Smooth corbel (11,5 cm)



**Mensola rigata (11,5 cm)**  
Striped corbel (11,5 cm)



cm 11,5

**Bastoncino liscio (11,5 cm)**  
Smooth strip (11,5 cm)



**Bastoncino rigato (11,5 cm)**  
Striped strip (11,5 cm)



**Mensola liscia (11,5 cm)**  
Smooth corbel (11,5 cm)



**Mensola rigata (11,5 cm)**  
Striped corbel (11,5 cm)



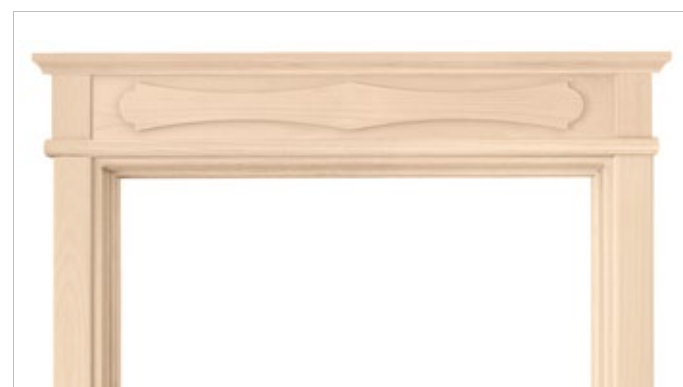

cm 6,4  
**Capitello Formelle con coprifili lisci**  
 "Formelle" doorhead with smooth casings



cm 11,5  
**Capitello Quadrato con Bastoncino liscio (11,5 cm)**  
 "Square" doorhead with Smooth strip (11,5 cm)



cm 11,5  
**Capitello Barocco con Bastoncino liscio (11,5 cm)**  
 "Barocco" doorhead with Smooth strip (11,5 cm)

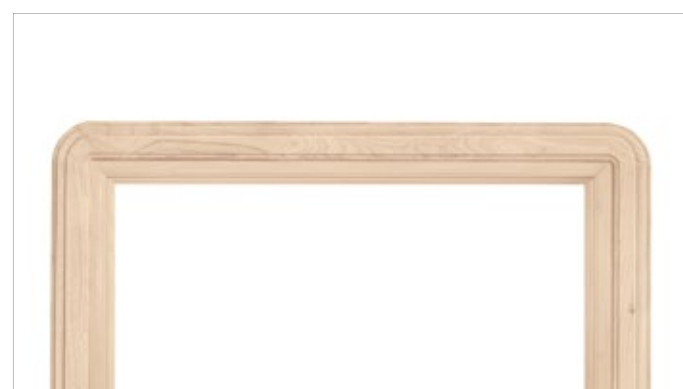

cm 6,4  
**Coprifili con angoli arrotondati**  
 Casings with rounded corners

Zoccolino  
 Plinth



**Varianti Capitello con coprifili speciali L. cm 11,5 completi di zoccolino**  
 Doorheads' variant with special casings 11,5 cm wide, with plinth



cm 11,5  
**Bastoncino liscio (11,5 cm)**  
 Smooth strip (11,5 cm)



**Bastoncino rigato (11,5 cm)**  
 Striped strip (11,5 cm)



**Mensola liscia (11,5 cm)**  
 Smooth corbel (11,5 cm)



**Mensola rigata (11,5 cm)**  
 Striped corbel (11,5 cm)



**Bastoncino rigato (11,5 cm)**  
 Striped strip (11,5 cm)



**Mensola liscia (11,5 cm)**  
 Smooth corbel (11,5 cm)



**Mensola rigata (11,5 cm)**  
 Striped corbel (11,5 cm)



**Bastoncino rigato (11,5 cm)**  
 Striped strip (11,5 cm)



**Mensola liscia (11,5 cm)**  
 Smooth corbel (11,5 cm)



**Mensola rigata (11,5 cm)**  
 Striped corbel (11,5 cm)



cm 6,4  
**Coprifili con blocchetti semplici**  
 Casings with simple corner blocks



cm 6,4  
**Coprifili con blocchetti torniti**  
 Casings with turned corner blocks





# Prima

Solidità e semplicità di linee per una collezione che coniuga forma e sostanza.

Solidness and simple lines for a collection that marries shape with substance.





Prima



# Prima

Solidità ed eleganza, robustezza e linea: quando la forma si coniuga con la sostanza, nasce la Collezione "Prima".

Una gamma ampia, tante creazioni in Tulipwood che, con le particolari e piacevoli cromie, si adattano ad ogni ambiente.

E a ogni personalità.

Solidness and elegance, sturdiness and design: when shape marries substance, the Prima collection comes to life. A wide range, with many creations in tulipwood, which, thanks to their special and pleasant chromatic tones, are suited to any surroundings.

As well as to any personality.

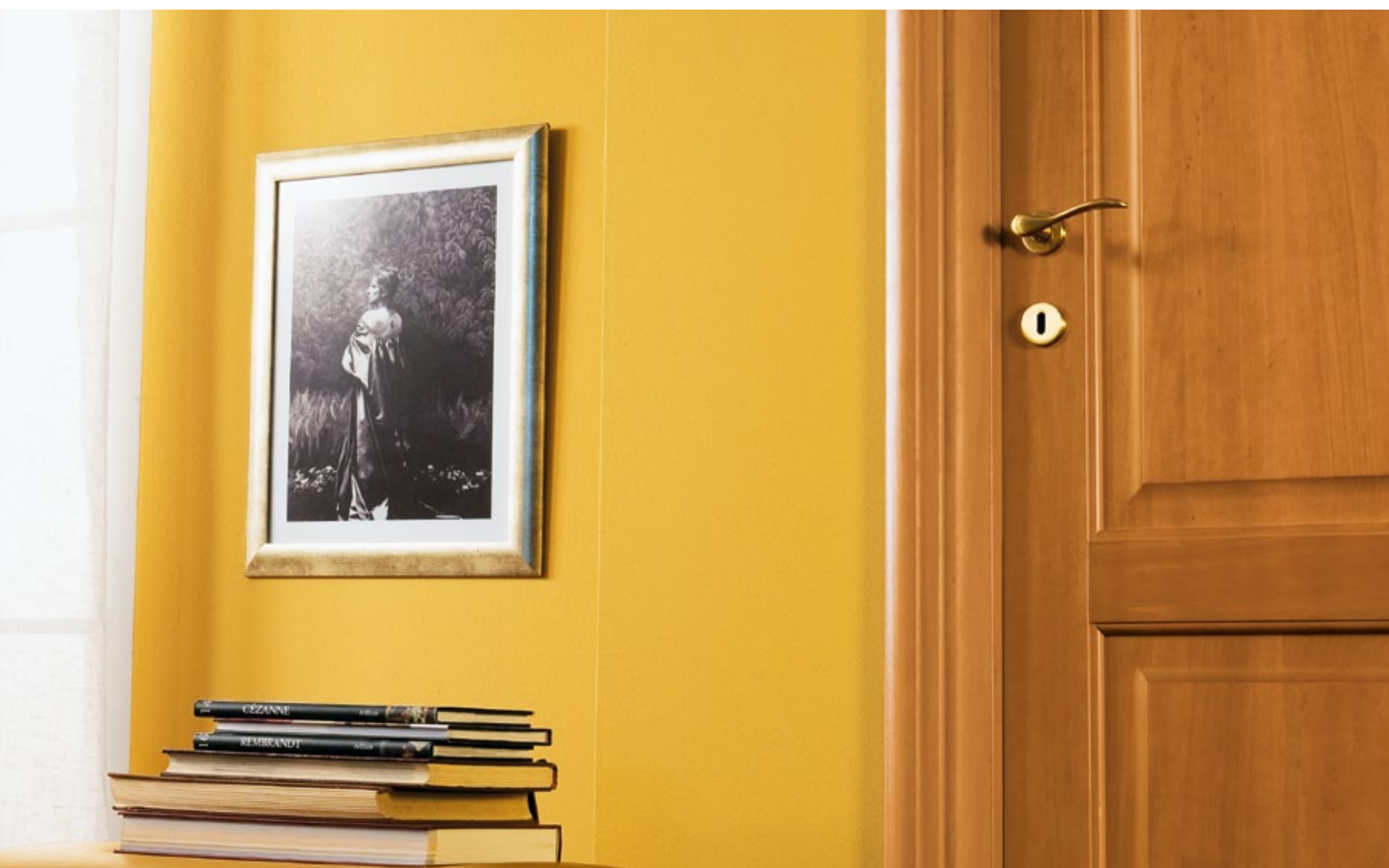

cod. P-14 Tulipwood tinto noce  
chiaro - coprifili standard.

code P-14 Tulipwood stained light  
walnut - standard casings.

# Prima

legnoform



cod. P-13 Tulipwood tinto  
ciliegio chiaro - cristallo inciso a  
Stella - coprifili standard.

code P-13 Tulipwood stained light  
cherry - glass bevelled detail Star  
standard casings.



cod. P-30 Tulipwood tinto ciliegio  
scuro - coprifili standard.

code P-30 Tulipwood stained dark  
cherry - standard casings.



cod. P-24 Tulipwood tinto ciliegio  
scuro - coprifili standard.

code P-24 Tulipwood stained dark  
cherry - standard casings.

# Prima

legnoform





cod. P-40 Tulipwood tinto noce  
chiaro - coprifili standard.  
code P-40 Tulipwood stained light  
walnut - standard casings.



cod. P-50 Tulipwood tinto noce  
chiaro - coprifili standard.  
code P-50 Tulipwood stained light  
walnut - standard casings.



cod. P-11 Tulipwood tinto noce  
scuro - coprifili standard.  
code P-11 Tulipwood stained dark  
walnut - standard casings.





# Prima

Porte in legno massello di Tulipwood con telaio tondo. Ogni modello è disponibile nella versione a 2 battenti. Coprifili a 45°. Solid Tulipwood doors with round frame. Each model is available in the double-door version. 45° casings.

## I Modelli - The Models

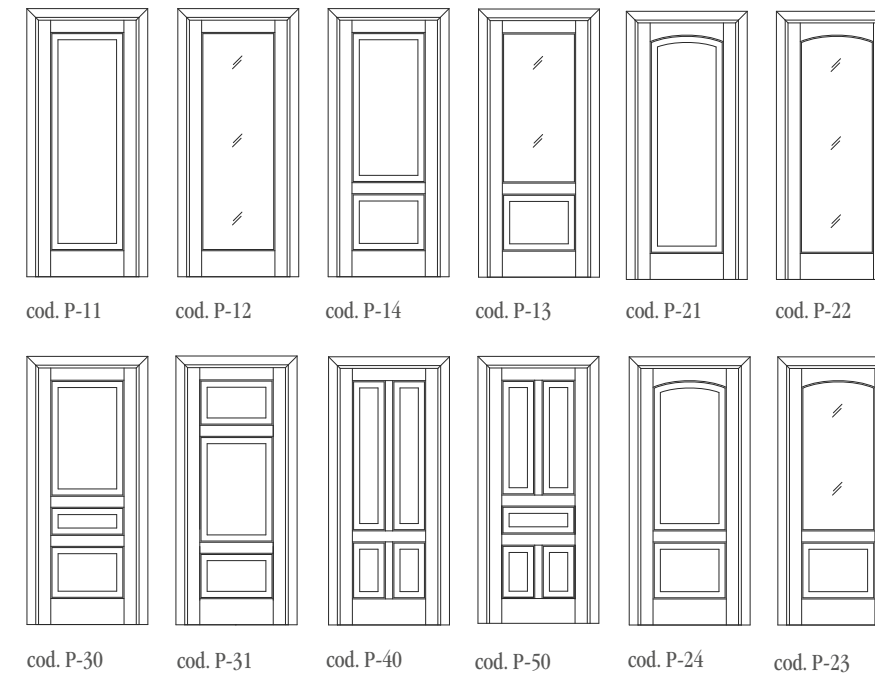

## Le Cerniere - The Hinges

Cerniera a pomella, in ottone  
Pinel hinge in brass



Finitura ottone satinato  
Mat brass finish

## Le Finiture Legno - The Wood Finishes



## I Cristalli - The Glass

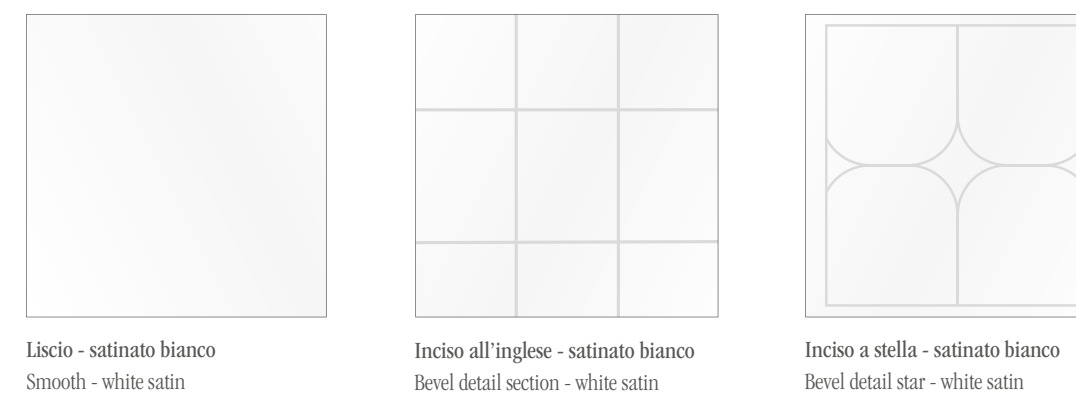

cod. P-31 Tulipwood tinto ciliegio chiaro - coprifili standard.

code P-31 Tulipwood stained light cherry - standard casings.

# Prima

legnoform





Alta Ebanisteria pag. 392

Legni & Lacche pag. 406

Il connubio tra artigianalità e ricerca di stile trova la sua massima espressione in queste collezioni dalle linee moderne ed originali.

The marriage of craftsmanship and style find its utmost expression in these collections characterized by modern and original lines.





Alta Ebanisteria



# Alta Ebanisteria

Il vertice di una ricerca, la massima espressione dell'artigianalità che si coniuga allo stile, alla ricchezza di forme e materiali.

Una collezione che rappresenta il meglio nell'ambito delle porte moderne, esaltata dall'originalità e dall'eleganza delle superfici a vetro, che disegnano linee morbide e sinuose.

Battente assemblato, telaio arrotondato e coprifili a capitello bombato: finiture pregiate che sono uno spettacolo nello spettacolo.

The height of refinement, the utmost expression of craftsmanship married to style and richness of shapes and materials.

A collection representing the crème de la crème of modern doors, enhanced by the originality and elegance of glass surfaces which draw soft and winding lines.

Assembled panel, rounded frame and bowed doorhead casings: a spectacular display of rich finishes.



cod. E-30 Alder tinto noce chiaro  
cristallo satinato bianco.

code E-30 Alder stained light  
walnut - white satin glass.

Alta Ebanisteria

legnoform





cod. E-10 Alder tinto noce  
chiaro.

code E-10 Alder stained  
light walnut.



cod. E-20 Alder tinto noce chiaro  
cristallo satinato bianco.

code E-20 Alder stained light  
walnut - white satin glass.



cod. E-40 Alder tinto noce  
scuro - inserti in metacrilato  
lenticolare trasparente.

code E-40 Alder stained dark  
walnut - clear lenticular  
methacrylate inserts.





cod. E-50 Alder tinto noce scuro  
cristallo satinato bianco.

code E-50 Alder stained dark  
walnut - white satin glass.





cod. E-30 Alder tinto ciliegio  
chiaro - cristallo satinato  
bianco.

code E-30 Alder stained light  
cherry white satin glass.



cod. E-40 Alder tinto ciliegio  
chiaro - inserti in metalcristallo  
lenticolare trasparente.

code E-40 Alder stained light  
cherry - clear lenticular  
methacrylate inserts.





cod. E-50 Alder tinto anilina bianco/rosa  
cristallo satinato bianco.

code E-50 Alder stained white/light pink aniline  
white satin glass.



cod. E-70 Alder tinto anilina azzurro/grigio  
cristallo satinato bianco.

code E-70 Alder stained light blue/grey aniline  
white satin glass.





# Alta Ebanisteria



Porte in legno massello di Nocino Americano Alder con battente assemblato, telaio arrotondato e coprifili con capitello bombato e raggiato sugli angoli. Ogni modello è disponibile nella versione a 2 battenti.

Solid wood Alder doors with jointed leaves, rounded frame and casings with bowed doorhead and rounded corners. Each model is available in the double-door version.

## I Modelli - The Models

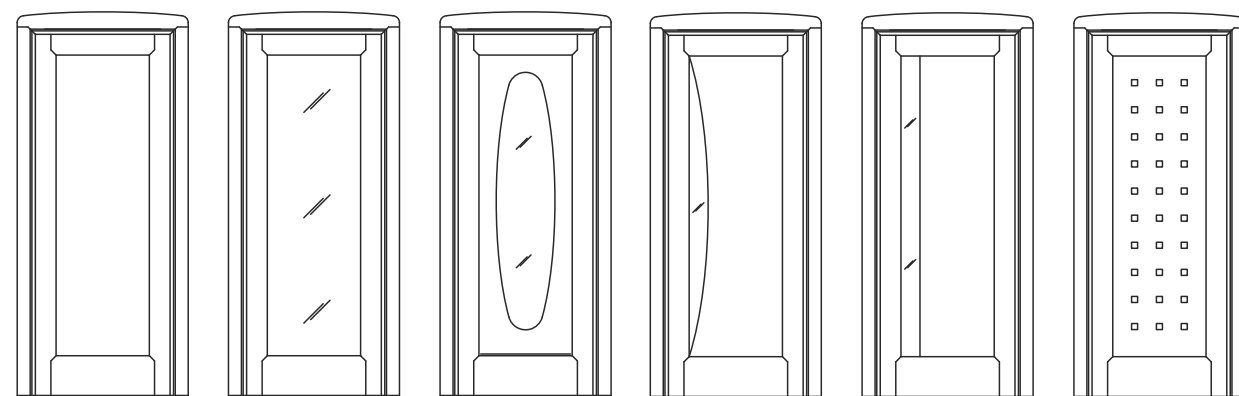

cod. E-10

cod. E-20

cod. E-30

cod. E-50

cod. E-70

cod. E-40

## Le Finiture Legno - The Wood Finishes



Alder tinto noce chiaro  
Alder stained light walnut

Alder tinto noce scuro  
Alder stained dark walnut

Alder tinto ciliegio chiaro  
Alder stained light cherry

Alder tinto ciliegio scuro  
Alder stained dark cherry

Alder anilina azzurro/grigio  
Alder aniline light blue/grey

Alder anilina bianco/rosa  
Alder aniline white/light pink

## I Cristalli - The Glass



Satinato bianco  
Satin white

Satinato fumè  
Satin grey

Satinato bronzo  
Satin bronze

Satinato verde  
Satin green

Satinato azzurro  
Satin light blue

## Le Cerniere - The Hinges

Cerniera a pomella, in ottone - Pintel hinge in brass



Finitura cromato lucido  
Polished chrome finish



Finitura cromato satinato  
Mat chrome finish



Finitura ottone lucido  
Polished brass finish



Finitura ottone satinato  
Mat brass finish







Legni &  
Lacche



# Le Lacche

Ambienti giovani, case per iniziare un percorso, una ricerca di stile nella semplicità. I pannelli sono lavorati per creare giochi di profondità, chiaroscuri che si affondano tra linee rigorose, aprendo spazi nello spazio. Il legno massello di Alder è laccato, in sei colori divertenti, di tendenza, dedicati a chi spontaneamente libera l'esigenza di lasciare un segno.

Youthful settings, homes for starting a journey, style through simplicity.

Panels are crafted to play with depths, light and shade effects within rigorous lines, opening spaces within space.

The solid alder wood is lacquered in six trendy fun colours chosen especially for those who openly eager to leave their mark.



cod. L-31 Alder laccato bianco  
coprifili piani.

code L-31 Alder white lacquered  
flat casings.





cod. L-32 Alder laccato grigio  
coprifili piani.

code L-32 Alder grey lacquered  
flat casings.



cod. L-12 Alder laccato grigio - cristallo inciso  
mod. Linee orizzontali - coprifili piani.

code L-12 Alder grey lacquered - etched glass mod.  
Horizontal lines - flat casings.



cod. L-34 Alder laccato grigio  
coprifili piani.

code L-34 Alder grey lacquered  
flat casings.





cod. L-12 Alder laccato bianco  
cristallo inciso mod. Cerchi  
coprifili piani.

code L-12 Alder white lacquered  
etched glass mod. Circles - flat  
casings.



cod. L-30 Alder laccato bianco  
coprifili piani.

code L-30 Alder white lacquered  
flat casings.





cod. L-31 Alder laccato verde  
coprifili piani.  
code L-31 Alder green lacquered  
flat casings.



cod. L-33 Alder laccato verde  
coprifili piani.  
code L-33 Alder green lacquered  
flat casings.





cod. L-34 Alder laccato corda  
coprifili piani.  
code L-34 Alder beige lacquered  
flat casings.



cod. L-32 Alder laccato corda  
coprifili piani.  
code L-32 Alder beige lacquered  
flat casings.





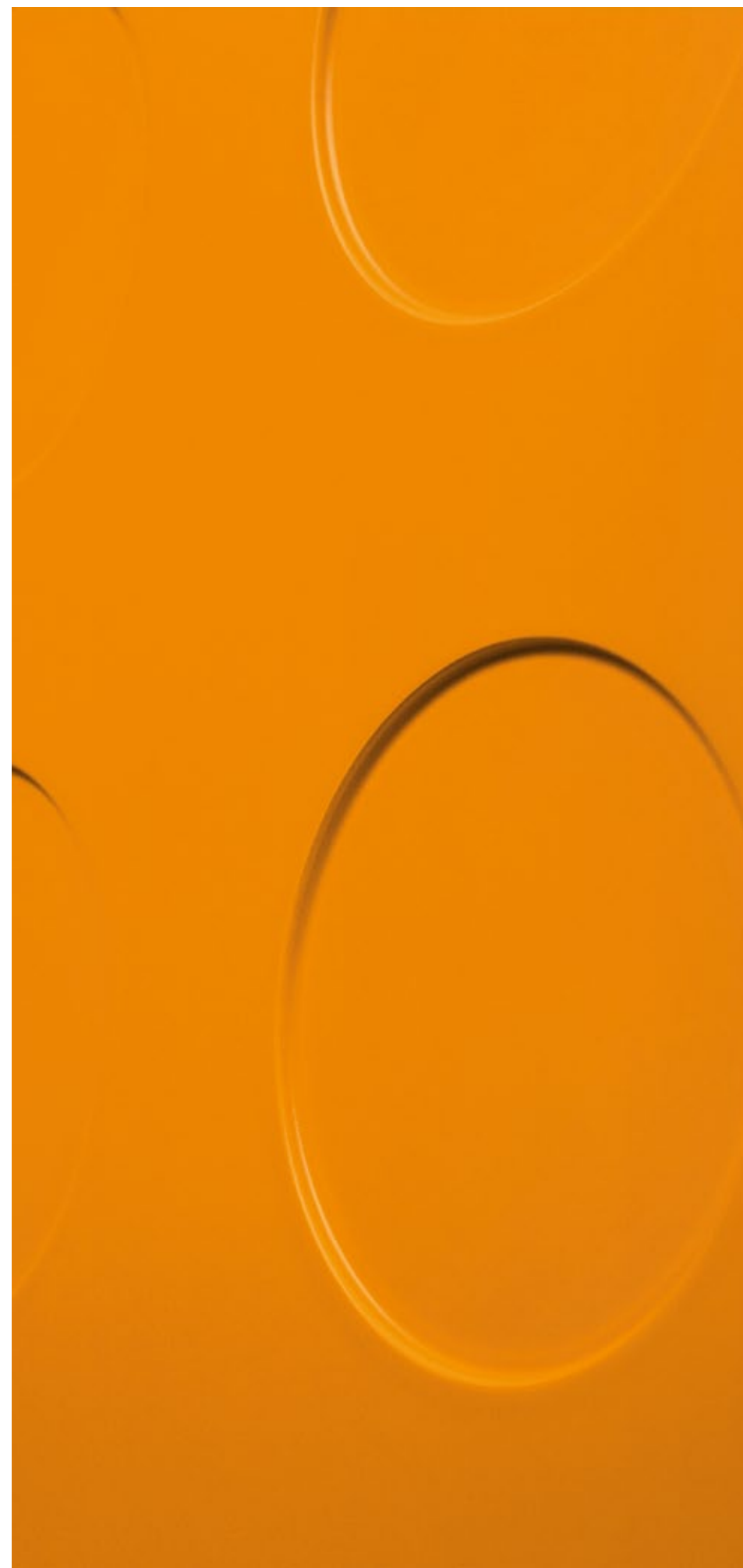

cod. L-30 Alder laccato arancio  
coprifili piani.

code L-30 Alder orange lacquered  
flat casings.

cod. L-33 Alder laccato arancio  
coprifili piani.

code L-33 Alder orange lacquered  
flat casings.





I Legni





cod. L-21 Alder tinto ciliegio chiaro  
coprifili piani.

code L-21 Alder stained light cherry  
flat casings.



cod. L-11 Alder tinto ciliegio chiaro  
coprifili piani.

code L-11 Alder stained light cherry  
flat casings.



cod. L-13 Alder tinto noce scuro - cristallo  
satinato bianco - coprifili piani.

code L-13 Alder stained dark walnut - white satin  
glass - flat casings.



cod. L-14 Alder tinto noce scuro  
coprifili piani.

code L-14 Alder stained dark walnut  
flat casings.





cod. L-20 Alder tinto noce chiaro  
cristalli satinati bianchi  
coprifili piani.

code L-20 Alder stained light  
walnut - white satin glass  
flat casings.



# Legni

Porte in legno massello di Nocino Americano Alder con battente assemblato, telaio inclinato ad invito e coprifili piani a 45°. Ogni modello è disponibile nella versione a 2 battenti.

Solid wood Alder doors with jointed leafs, invitingly angled frame and 45° flat casings. Each model is available in the double-door version.

## I Modelli - The Models

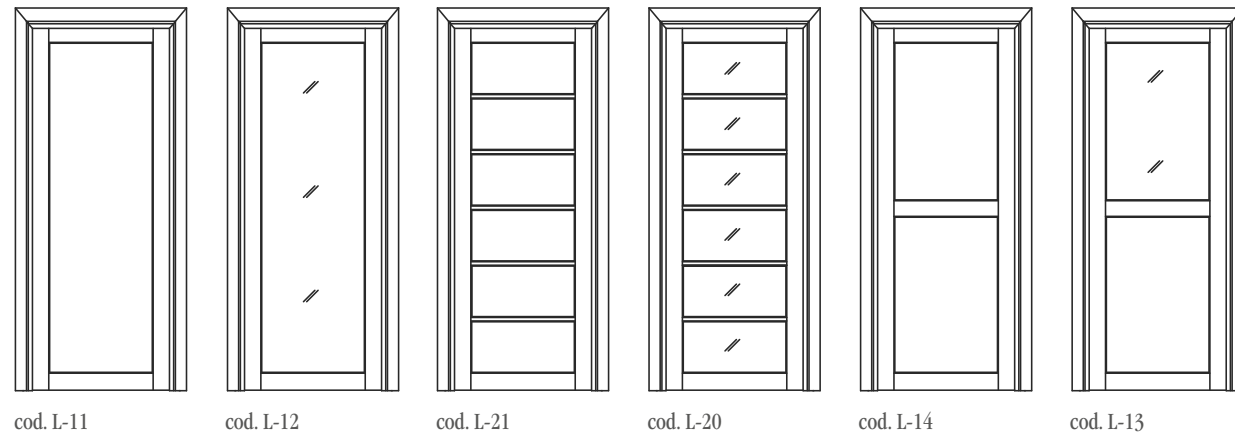

cod. L-11      cod. L-12      cod. L-21      cod. L-20      cod. L-14      cod. L-13

## Le Finiture Legno - The Wood Finishes



Alder tinto noce chiaro  
Alder stained light walnut      Alder tinto noce scuro  
Alder stained dark walnut      Alder tinto ciliegio chiaro  
Alder stained light cherry      Alder tinto ciliegio scuro  
Alder stained dark cherry

## I Cristalli - The Glass



Satinato bianco  
Satin white      Satinato fumè  
Satin grey      Satinato bronzo  
Satin bronze      Satinato verde  
Satin green      Satinato azzurro  
Satin light blue

## Le Cerniere - The Hinges

Cerniera a pomella in ottone/Pintel hinge in brass



Finitura cromato lucido  
Polished chrome finish

Finitura cromato satinato  
Mat chrome finish

Finitura ottone lucido  
Polished brass finish

Finitura ottone satinato  
Mat brass finish

# & Lacche

Porte in legno massello di Nocino Americano Alder con battente assemblato, pannello in mdf, telaio inclinato ad invito e coprifili piani a 45°. Ogni modello è disponibile nella versione a 2 battenti.

Solid wood Alder doors with jointed leafs, mdf panel, invitingly angled frame and 45° flat casings. Each model is available in the double-door version.

## I Modelli - The Models

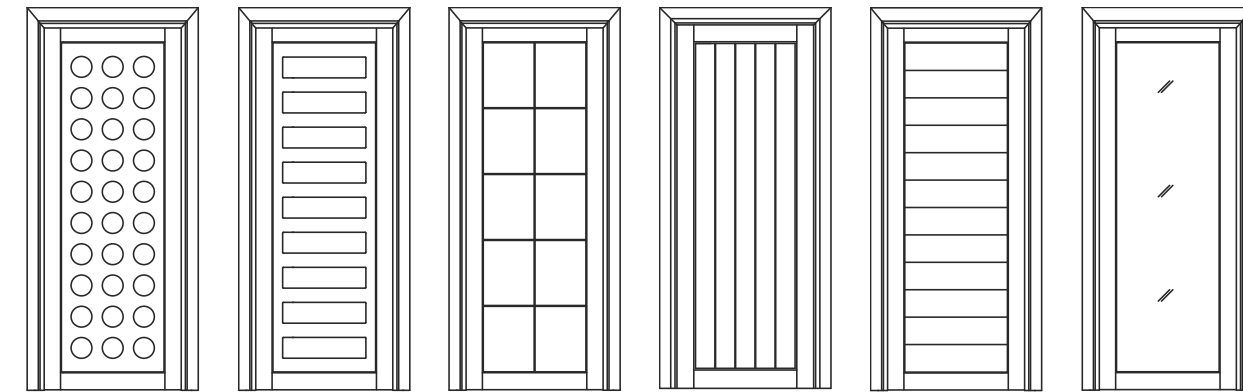

cod. L-30      cod. L-31      cod. L-32      cod. L-33      cod. L-34      cod. L-12

## Le Finiture Laccate - The Lacquered Finishes



Alder laccato bianco  
Alder white lacquered      Alder laccato corda  
Alder beige lacquered      Alder laccato grigio  
Alder grey lacquered      Alder laccato verde  
Alder green lacquered      Alder laccato arancio  
Alder orange lacquered      Alder laccato ocra  
Alder ochre lacquered

## I Cristalli Incisi - The Etched Glass

Satinati bianchi/White satin



mod. Cerchi  
mod. Circles      mod. Rettangoli  
mod. Rectangles      mod. Riquadri  
mod. Squares      mod. Linee Verticali  
mod. Vertical lines      mod. Linee Orizzontali  
mod. Horizontal lines

## Le Cerniere - The Hinges

Cerniera a pomella in ottone/Pintel hinge in brass



Finitura cromato lucido  
Polished chrome finish

Finitura cromato satinato  
Mat chrome finish

Finitura ottone lucido  
Polished brass finish

Finitura ottone satinato  
Mat brass finish



**legnoform**  
Lo stile italiano apre le porte





**Legnoform ringrazia:**

[www.flexform.it](http://www.flexform.it)  
[www.besana.it](http://www.besana.it)  
[www.pentalight.it](http://www.pentalight.it)  
[www.novita-import.it](http://www.novita-import.it)  
[www.lafabbricadelverde.it](http://www.lafabbricadelverde.it)  
[www.diamantinidomeniconi.it](http://www.diamantinidomeniconi.it)  
[www.plinioilgiovane.it](http://www.plinioilgiovane.it)  
[www.cantori.it](http://www.cantori.it)  
[www.cabiate.it](http://www.cabiate.it)  
[www.ego-alter.it](http://www.ego-alter.it)  
[www.idpitalia.it](http://www.idpitalia.it)  
[www.tisca.it](http://www.tisca.it)  
[www.danesemilano.com](http://www.danesemilano.com)  
[www.christopherpisk.it](http://www.christopherpisk.it)  
[www.martinimobili.it](http://www.martinimobili.it)  
[www.luce-design.it](http://www.luce-design.it)

**Progetto, Comunicazione**  
lucepensiero.com

**Art Direction, Art Work**  
lucepensiero.com

**Riprese Fotografiche Ambientate**  
lucepensiero.com

**Riprese Fotografiche di Prodotto**  
Claudio Salis clodsalis.com

**Styling**  
Vanessa Pisk  
Elisabetta Giannullo (coll. Liberty)

**Post Produzione**  
Claudio Salis clodsalis.com  
Stefano Festini Mira

**Stampa**  
L'Artistica Savigliano





# legnoform

Lo stile italiano apre le porte

Legnoform Srl  
12030 Marene (Cn) Italy  
via Marconi, 122

T. +39 0172 742014  
F. +39 0172 742940

[info@legnoform.it](mailto:info@legnoform.it)  
[www.legnoform.it](http://www.legnoform.it)  
[www.portek.it](http://www.portek.it)

Legnoform srl è esclusiva detentrica dei diritti d'autore di questo catalogo e dei modelli in esso riprodotti. Ne è quindi vietata la riproduzione totale e parziale.

I colori riportati in questo catalogo hanno valore puramente indicativo.  
La stampa non consente una perfetta riproduzione delle tonalità.

Legnoform srl reserves all rights to this catalogue and reproduction thereof in whole or in part is therefore strictly prohibited.

Colours featured in this catalogue are not binding. Printing does not allow a perfect shade reproduction.